

Crawler Crane

# LR 1250.1

EN

LR 1004.03.07/08



# LIEBHERR

<b>Concept and characteristics</b>	3
<b>Technical description</b>	6
<b>Dimensions</b>	8
<b>Transport dimensions and weights</b>	9
<b>Self-assembly system</b>	14
<b>Boom combinations</b>	16
<b>Main boom 2320.xx</b>	18
<b>Luffing jib 1713.xx</b>	20
<b>Luffing jib 1916.xx</b>	26
<b>Fixed jib 1008.xx</b>	32
<b>Fixed jib 0806.xx</b>	35
<b>Fixed jib 0906.21</b>	38

## Remarks

- The load capacities stated are valid for lifting operation only (corresponding with crane classification according to ISO 4301-1, crane group A1).
- Machine is standing on firm, horizontal ground.
- The weight of the lifting device (pulley block, hoist ropes, shackles etc.) must be deducted from the load capacity.
- Additional equipment on boom (e.g. walkways) must be deducted from the load capacity.
- The max. admissible wind speed can be preselected in the LML software and referred to in the load chart.
- Working radii are measured from centre of swing ring and under load.
- The lifting capacities are valid for 360 degrees of swing.
- Calculation of stability under load is based on ISO 4305 Table 1 + 2 + 3, tipping angle 4°.
- The steel structures are calculated according to EN 13001-1; EN 13001-2.
- The last digits of the given dimensions are rounded to 0 and 5 and may differ from the actual dimensions.
- Weights may vary depending on the delivered configuration of the machine filling level of the tanks as well as generally valid tolerances.
- The illustrations in this brochure may include options which are not within the standard scope of supply of the machine.

# Concept and characteristics

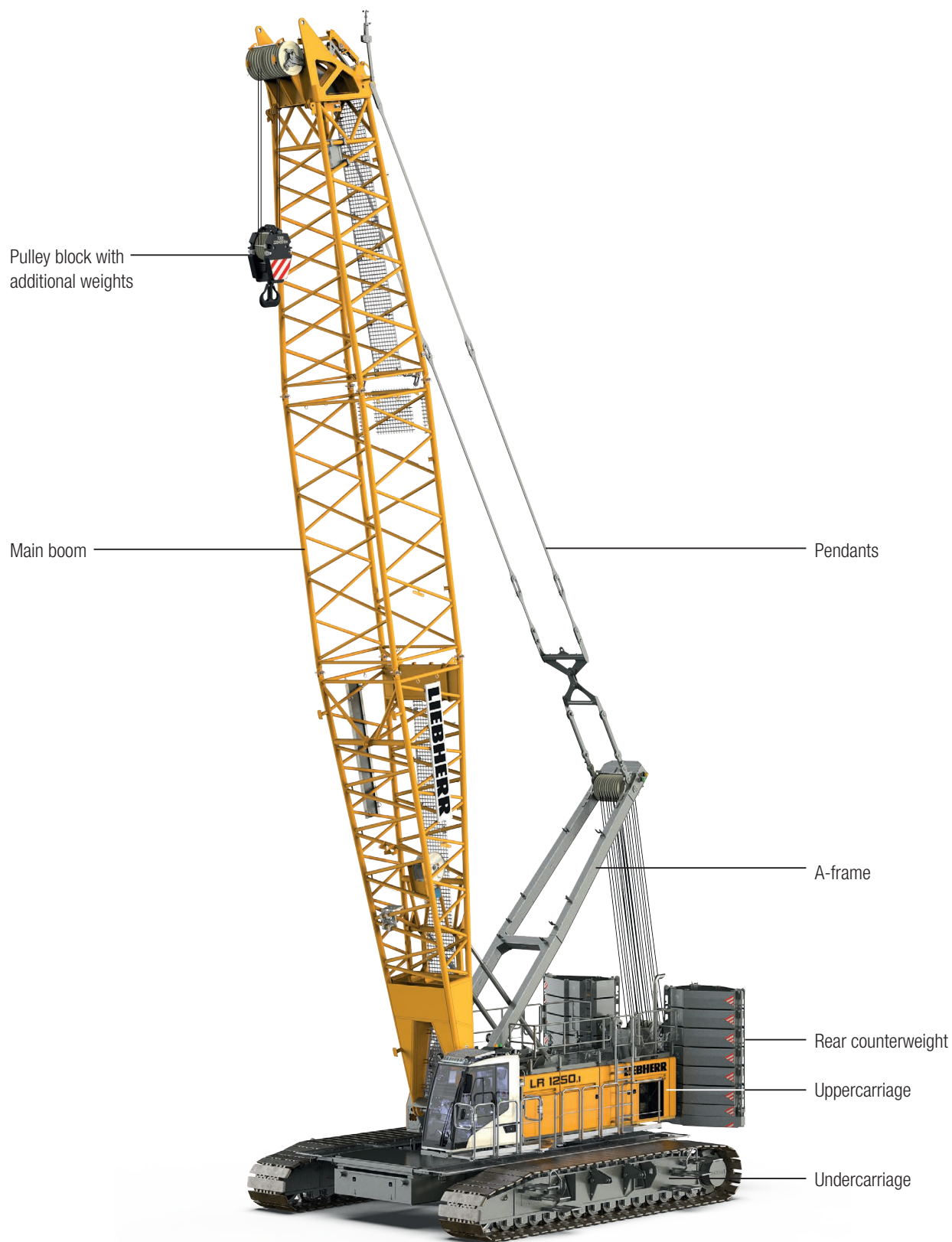

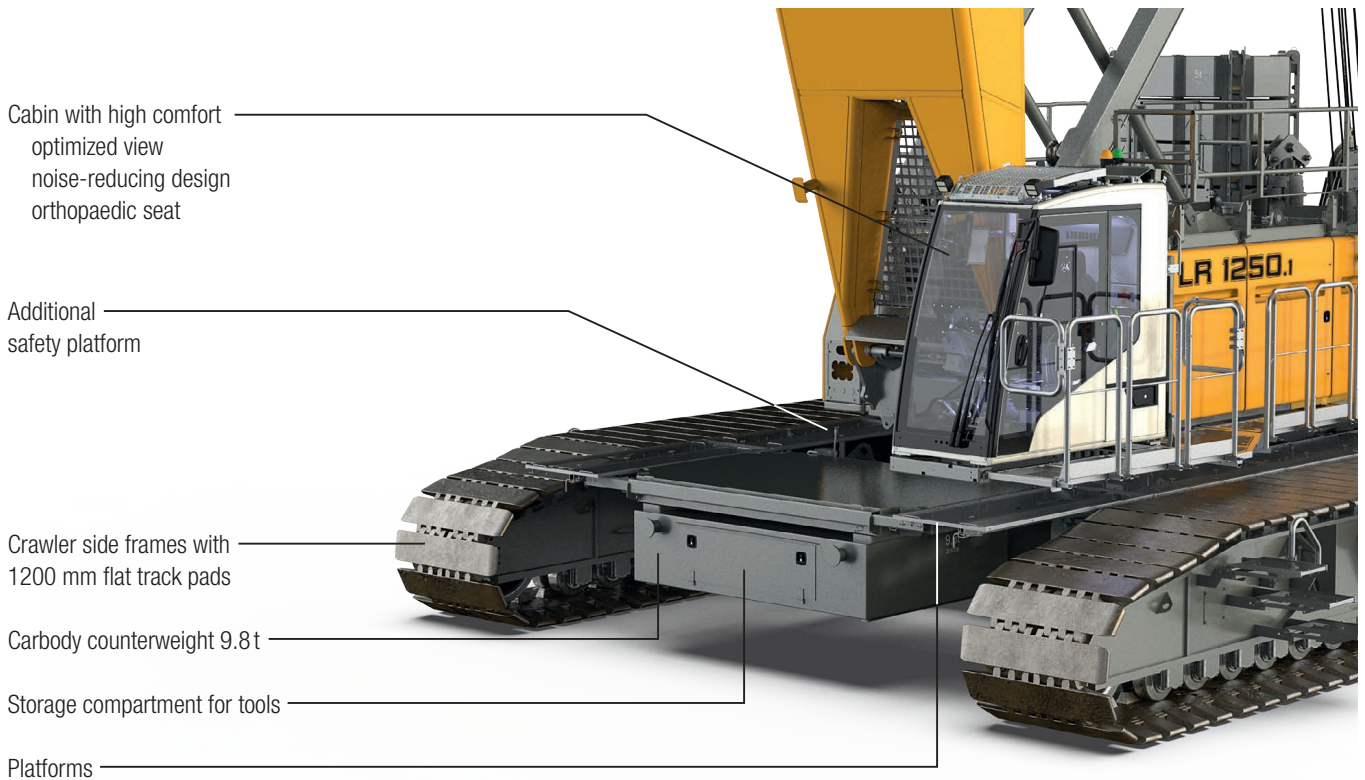

### High performance

A strong, efficient and reliable diesel engine of the newest generation provides high performance and enables several movements to be carried out simultaneously.

### Ground pressure

The actual ground pressure is calculated according to the configuration and position of the machine and displayed in the operator's cabin. Using the optional Liebherr Crane Planner the actual ground pressure can already be calculated and displayed in the planning stage.

### Cabin with high comfort

Optimised field of vision combined with enhanced comfort: an orthopaedic operator's seat with heating and cooling functions, as well as precise and ergonomic controls are included.

### Control

Easy and intuitive handling of control, service and machine functions through a large, clear colour monitor. Built for extreme environmental conditions.

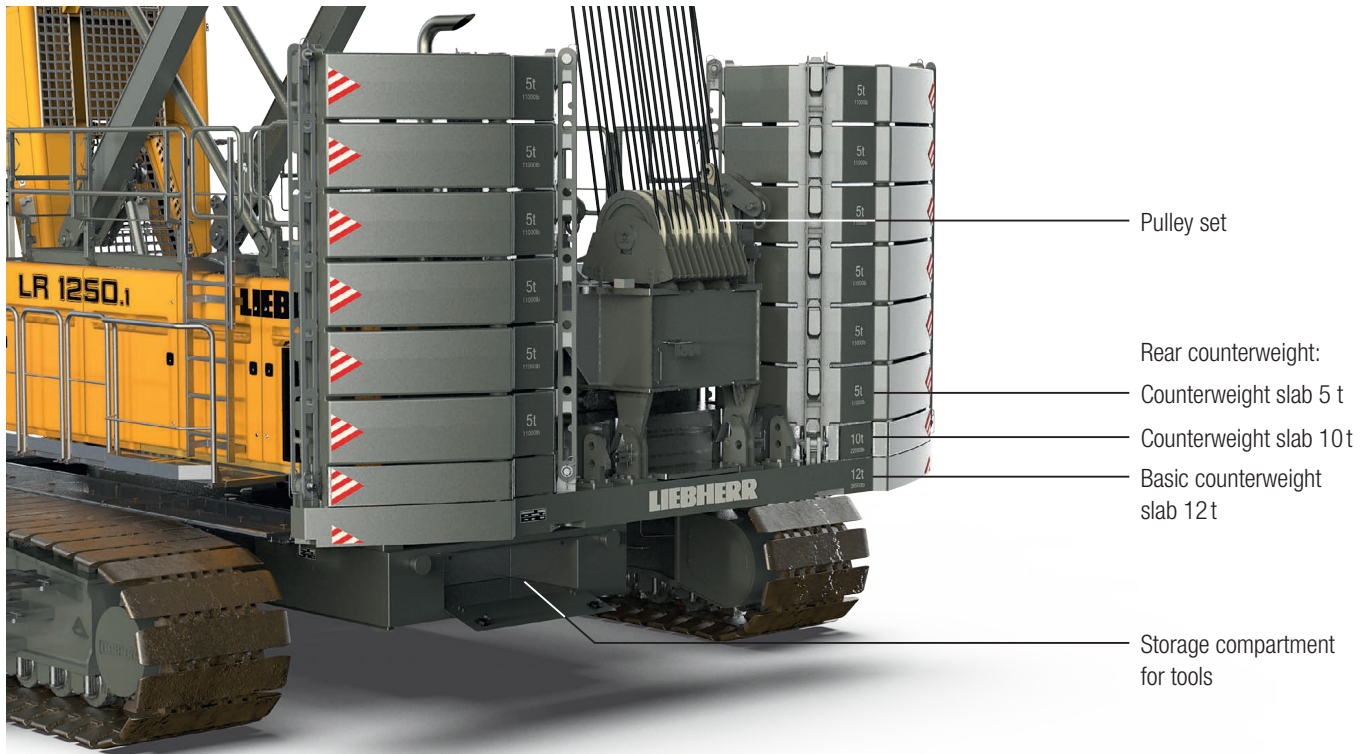

Pulley set

Rear counterweight:

Counterweight slab 5 t

Counterweight slab 10 t

Basic counterweight slab 12 t

Storage compartment for tools

### Efficient self-assembly system and short assembly times

The self-assembly system enables safe, independent and quick assembly/disassembly of the crawler side frames, the carbody and rear counterweights, as well as boom elements.

### Mobility

Crane parts are optimized for transportation. The maximum transport width is 3 m.

### Easy service

The design ensures easy maintenance and service as well as safe access to the components.

### Boom/jib

A variety of boom systems and configurations allow for optimum operation on the most diverse jobsites.

# Technical description



## Diesel engine

<b>Power rating according to ISO 9249</b>	230 kW (308 hp) at 1700 rpm
<b>Engine type</b>	Liebherr D 944 A7-04
<b>Fuel tank capacity</b>	790 l with continuous level indicator and reserve warning
<b>Exhaust certification</b>	97/68 EC Stage IV; EPA/CARB Tier 4f 97/68 EC Stage V; EPA/CARB Tier 4f ECE-R.96 Power Band H non-certified emission standard



## Noise measurement data and vibration

<b>Noise emission</b>	according to 2000/14/EC directive	
Emission sound pressure level $L_{PA}$	72.9 dB(A)	(in the cabin)
Guaranteed sound power level $L_{WA}$	107 dB(A)	(of the machine)
<b>Vibration transmitted to the machine operator</b>	< 2.5 $m/s^2$	(to the hand-arm system)
	< 0.5 $m/s^2$	(to the whole body)



## Hydraulic system

<b>Hydraulic pumps</b>	double axial displacement pump in open loop hydraulic system allows all functions to be operated simultaneously automatic working pressure cut-off to minimize peak pressure
<b>Hydraulic oil tank capacity</b>	650 l
<b>Max. working pressure</b>	350 bar
<b>Hydraulic oil</b>	electronic monitoring of alle filters use of synthetic environmentally friendly oil



## Control

<b>Control system</b>	includes all control and monitoring functions, designed to withstand extreme environmental conditions and heavy construction tasks
<b>Display</b>	high resolution monitor in the operator's cabin, clear display of complete machine operating data, warnings and failure indications in the required language
<b>Operation</b>	several movements can be performed simultaneously thanks to electro-hydraulic proportional control, all categories of loads can be positioned with utmost precision



## Crawlers

<b>Drive system</b>	with fixed axial piston hydraulic motors
<b>Crawler side frames</b>	maintenance-free, with hydraulic chain tensioning device
<b>Brake</b>	hydraulically released, spring-loaded multi-disc holding brake
<b>Drive speed</b>	0-1.6 km/h
<b>Flat track pads</b>	width 1200 mm



## Swing gear

<b>Drive system</b>	with fixed axial piston hydraulic motors, planetary gearbox, pinion
<b>Swing ring</b>	roller bearing with external teeth
<b>Brake</b>	hydraulically released, spring-loaded multi-disc holding brake
<b>Swing speed</b>	0-3 rpm continuously variable
<b>Speed control</b>	both swing modes are possible – speed control or free swing for speed control: a multi-disc holding brake locks automatically at zero swing motion.



## Hoisting gear

<b>Standard crane winches 1 + 2</b>	internal low-maintenance planetary gearbox in oil bath, load support by the hydraulic system, spring-loaded, multi-disc holding brake, pressure controlled, variable flow hydraulic motors for the main winches, full utilisation of engine power as the winch speed is automatically adjusted to suit the respective line pull
Line pull in the 7th layer	120 kN
Rope diameter	26 mm
Drum diameter	580 mm
Rope speed	0-136 m/min
Rope capacity in 7 layers	489 m
<b>Option – winch with free fall</b>	free fall: clutch and braking functions are provided by the service brake (low wear and maintenance-free multi-disc brake in compact design)







## Boom/jib luffing winches

<b>Main boom</b>	
Line pull	max. 217 kN
Rope diameter	24 mm
Boom luffing	15-86° in 130 s
<b>Jib</b>	
Line pull	max. 105 kN
Rope diameter	20 mm
Jib luffing	15-78° in 51 s

## Operating weight

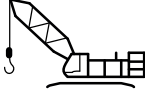
<b>Composition of operating weight</b>	basic machine with crawlers Winches 1 + 2 (incl. ropes), A-frame 20m main boom, consisting of boom foot (10m), boom head (7m) and boom section (3m) 82.3t rear counterweight (12 × 5t + 1 × 12t + 1 × 10t + 0.3t) 36t carbody counterweight (2 × 9.8t + 2 × 8.3t) 250t pulley block
<b>Total weight</b>	approx. 210t

## Operation modes

	 Lifting mode	 Grab mode	 Personnel lifting mode
 Land	✓	✓	✓
 Floating structure (barge operation)	✓	✓	✓*

\* only valid for jack-up barges

## Optional equipment

### Basic machine

Main winches 12 t with free fall  
Painting in customer design  
Load hook 12.5/40/80/100/160/250 t

### Economy and ecology

Eco-Silent Package  
Aux. power unit (APU, 2.8 kW)

### Boom/jib

Luffing jib: luffing winch  
Carbon fibre pendants

### Boom/jib other

Walkway for main boom foot, incl. fall protection  
Walkway for main boom head, incl. fall protection  
Rope guide for main boom walkway, incl. fall protection  
Additional fall protection harness for 1 person  
Walkways for main boom sections 3/6/12 m  
Walkways for main boom sections 3/6/12 m, incl. fall protection

### Application packages

Operation mode: personnel lifting (O)  
Operation mode: barge operation (O)  
Operation mode: foundation work (O)  
Operation mode: wind speed pre-selection (S)  
Operation mode: travelling with load (S)  
Winch synchronization  
Radio remote control  
Rope reeving function via radio remote control  
Assembly radio remote control  
Use of luffing jib winch as auxiliary winch  
Tagline winch 2 t free fall  
Main winch constant tension for one winch  
Two hook operation  
Cabin elevator 6 m hydraulic

### Special features

Crane Planner 2.0  
LiDAT

### Self-assembly system

Jack-up system standard / telescopic  
Self-assembly system counterweight  
Self-assembly cylinder  
Reeving winch  
Track shifting hydraulic

### Service package

Refuelling pump diesel / AdBlue  
Cold package -25 °C / -40 °C  
Hydraulic oil bypass filter  
Central lubrication swing ring bearings / outside  
Liebherr hydraulic oil plus (longlife & bio)  
Liebherr hydraulic oil plus arctic (longlife & bio)  
Liebherr hydraulic oil plus arctic (longlife)

### Safety features

Assistance system: Boom Up-and-Down Aid  
Assistance system: Horizontal Load Path  
Assistance system: Vertical Line Finder  
Assistance system: Ground Pressure Indication and Visualization  
Rear and side view cameras  
Winch camera  
Zoom camera at boom head  
Platforms and railings on uppercarriage 570 mm  
Additional access ladder for boom assembly  
Railings on rooftop foldable  
Railings for cabin platform  
Vandalism cabin protection  
Cabin protection roof, FOPS level 1  
Lifting height indication for both hoist winches  
Plug&Play diesel-hydraulic back-up unit 18.4 kW  
Swing and boom radius limit device  
Aircraft warning light  
Swing warning light  
Lightning rod  
Mechanical angle display  
Air intake shut-off valve  
Access control

### Operator's comfort

Additional access ladder  
Additional floodlights  
Cabin air conditioner  
Cabin tilting device hydraulic  
Gear oil level warning  
Litronic additional language

(S) standard, (O) option

# Dimensions

Basic machine with undercarriage

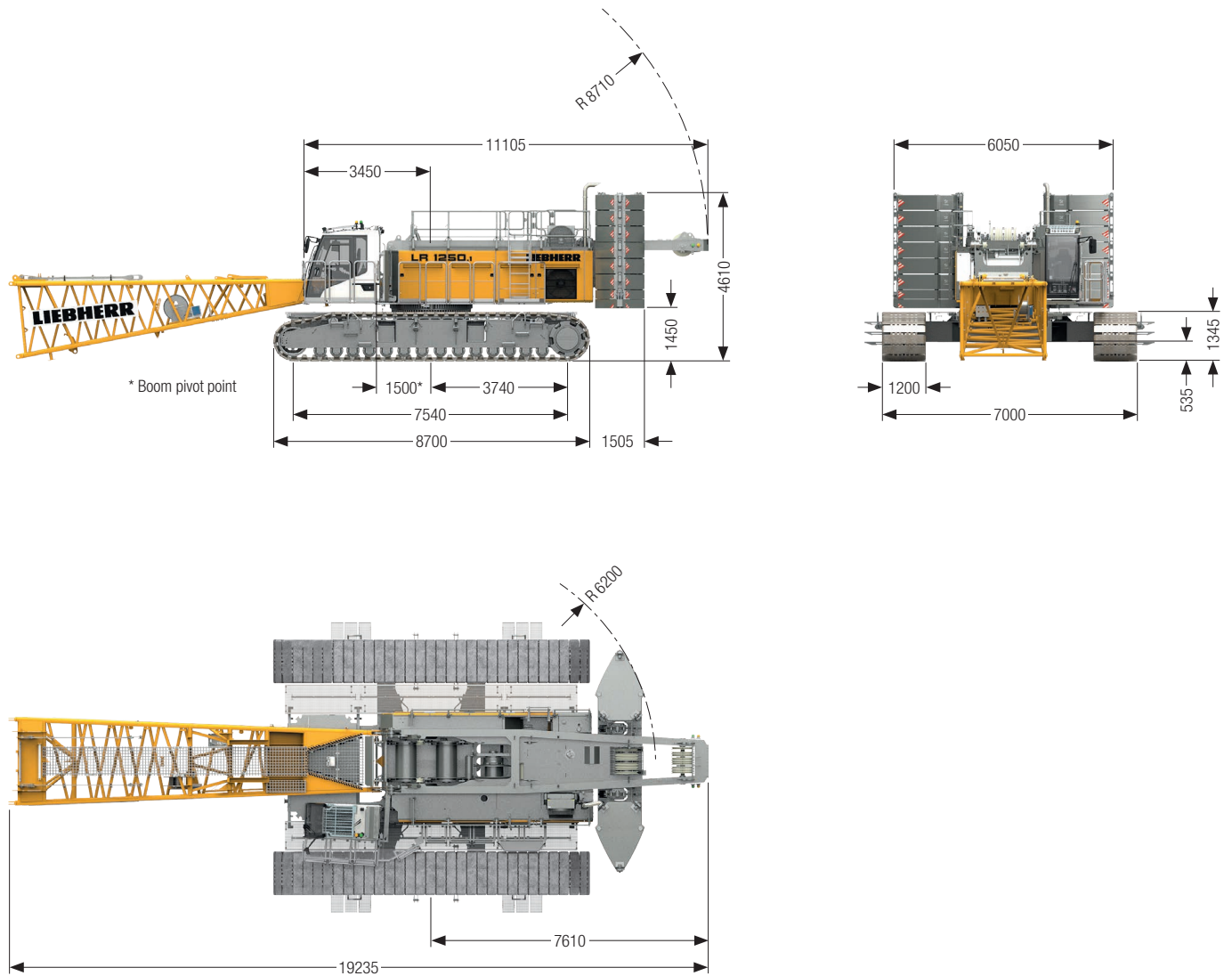



# Transport dimensions and weights

## Basic machine and main boom 2320.xx

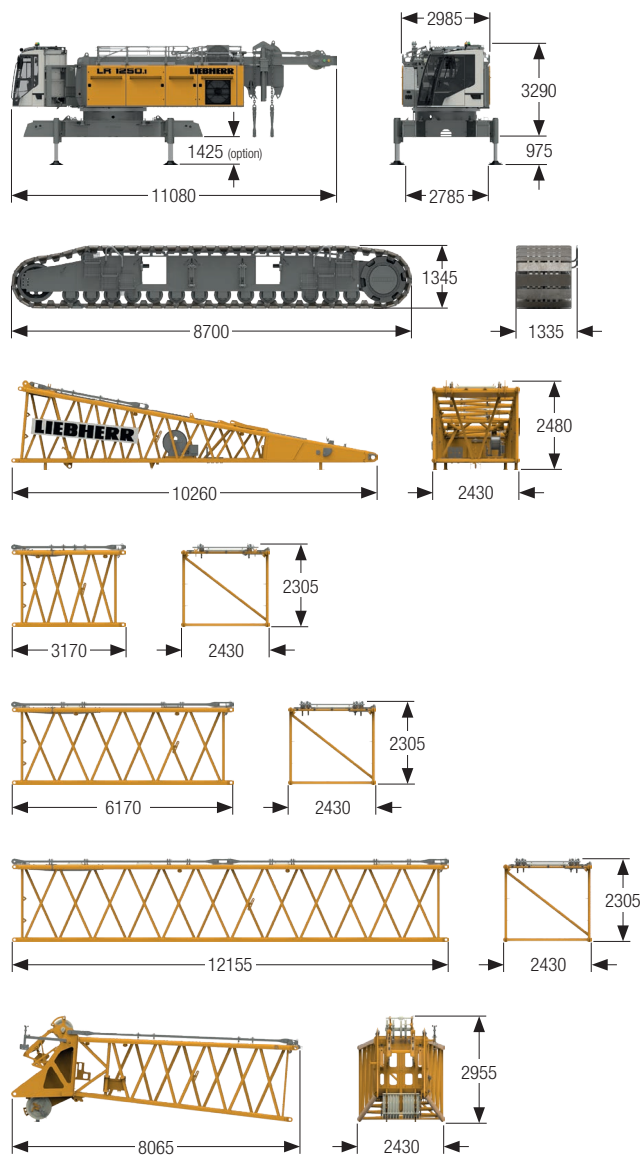

### Basic machine

Weight without hoist rope	kg	37228
Weight of hoist ropes	kg/m	3.4
with A-frame 1, winches 1 + 2 (2x 120 kN), without boom foot, without rear counterweight, without carbody counterweight and crawler side frames		

### Crawler side frame

Weight flat track pads 1200 mm	kg	19658
--------------------------------	----	-------

### Boom foot 10 m (No. 2320.25)

Weight including winch	kg	4827
Weight without winch	kg	3737

### Boom section 3 m (No. 2320.23)

Weight including boom pendants	kg	871
Weight including boom and jib pendants	kg	959

### Boom section 6 m (No. 2320.23)

Weight including boom pendants	kg	1344
Weight including boom and jib pendants	kg	1497

### Boom section 12 m (No. 2320.23)

Weight including boom pendants	kg	2434
Weight including boom and jib pendants	kg	2737

### Boom head 7 m (No. 2320.23)

Weight including boom pendants	kg	3613
--------------------------------	----	------

## Transport option 2320.xx/1916.xx

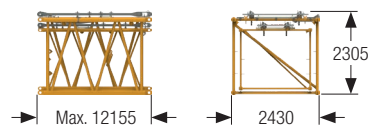

### Transport option (No. 2320.xx/1916.xx)

No. 2320.xx/1916.xx	m	3 / 3	6 / 6	12 / 12
Weight including pendants	kg	1453	2228	4027

## Fixed jib 1008.xx

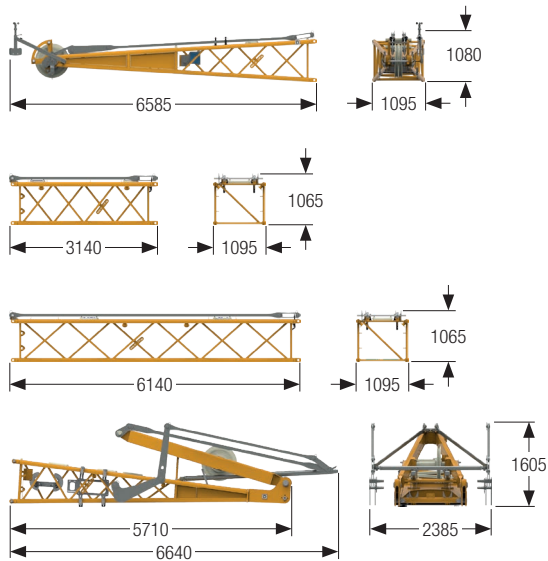

### Jib head 5.5 m (No. 1008.20)

Weight including pendants	kg	873
---------------------------	----	-----

### Jib section 3 m (No. 1008.17)

Weight including pendants	kg	267
---------------------------	----	-----

### Jib section 6 m (No. 1008.17)

Weight including pendants	kg	448
---------------------------	----	-----

### Jib foot 5.5 m with A-frame (No. 1008.20)

Weight including pendants	kg	2110
---------------------------	----	------

## Fixed jib 0806.xx

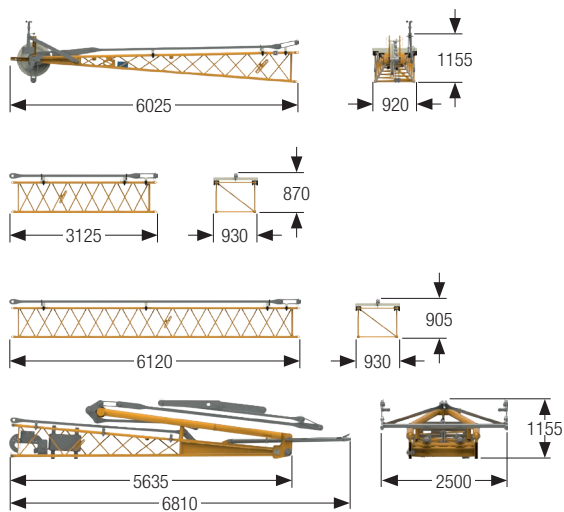

### Jib head 5.5 m (No. 0806.16)

Weight including pendants	kg	442
---------------------------	----	-----

### Jib section 3 m (No. 0806.15)

Weight including pendants	kg	141
---------------------------	----	-----

### Jib section 6 m (No. 0806.15)

Weight including pendants	kg	249
---------------------------	----	-----

### Jib foot 5.5 m with A-frame (No. 0806.16)

Weight including pendants	kg	1017
---------------------------	----	------

## Fixed jib 0906.21

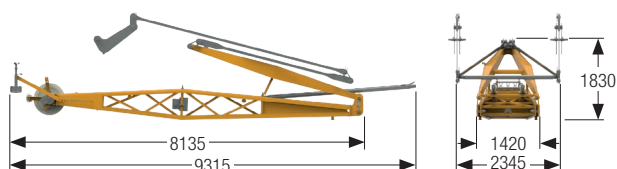

### Fixed jib 7 m (No. 0906.21)

Weight including pendants	kg	2413
---------------------------	----	------

## Luffing jib 1713.xx

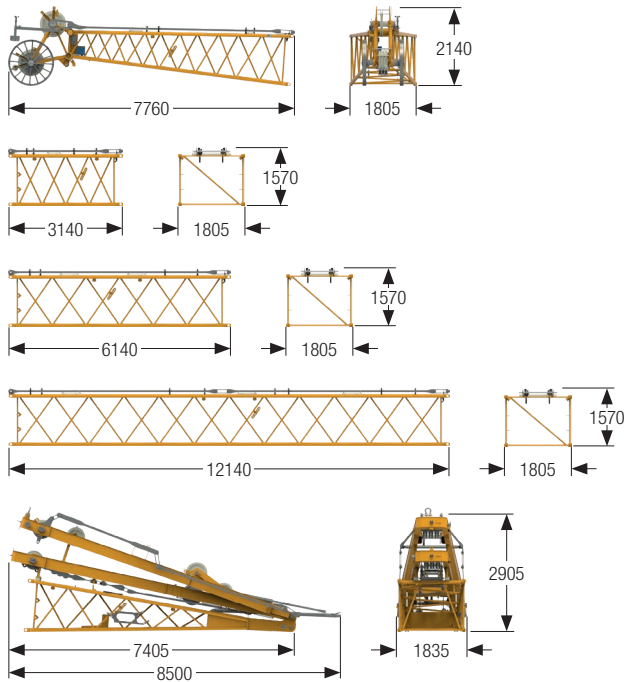

### Jib head 7 m (No. 1713.21)

Weight including pendants	kg	1376
---------------------------	----	------

### Jib section 3 m (No. 1713.18)

Weight including pendants	kg	394
---------------------------	----	-----

### Jib section 6 m (No. 1713.18)

Weight including pendants	kg	624
---------------------------	----	-----

### Jib section 12 m (No. 1713.18)

Weight including pendants	kg	1122
---------------------------	----	------

### Jib foot 7 m with A-frames 2 + 3 (No. 1713.22)

Weight including pendants	kg	4763
---------------------------	----	------

## Luffing jib 1916.xx

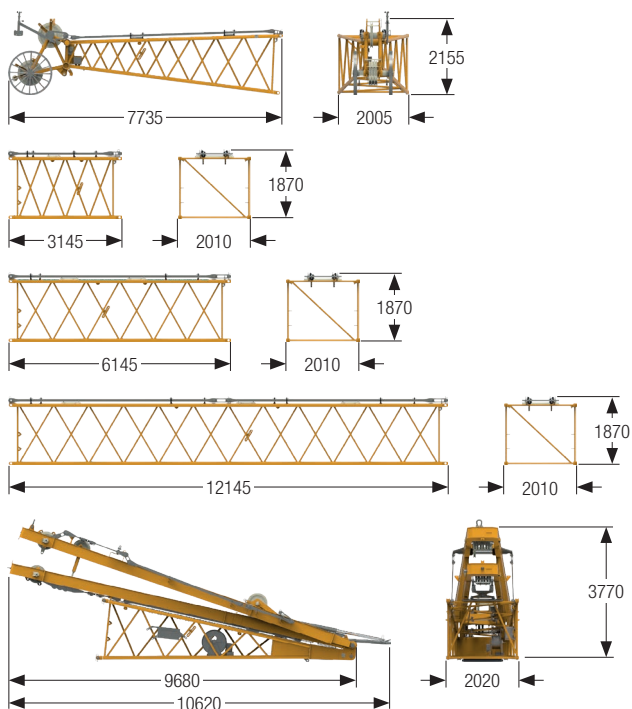

### Jib head 7 m (No. 1916.21)

Weight including pendants	kg	1520
---------------------------	----	------

### Jib section 3 m (No. 1916.18)

Weight including pendants	kg	494
---------------------------	----	-----

### Jib section 6 m (No. 1916.18)

Weight including pendants	kg	731
---------------------------	----	-----

### Jib section 12 m (No. 1916.18)

Weight including pendants	kg	1287
---------------------------	----	------

### Jib foot 7 m with A-frames 2 + 3 (No. 1916.22)

Weight including pendants	kg	6237
---------------------------	----	------

# Counterweight

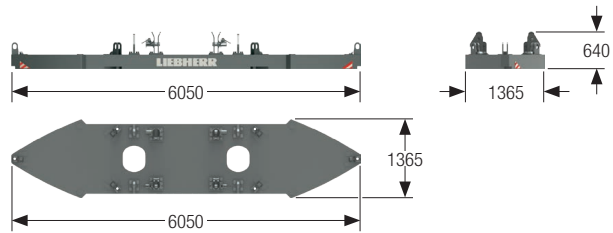

## Basic counterweight slab without tie-down (1x)

Weight	kg	12000
--------	----	-------

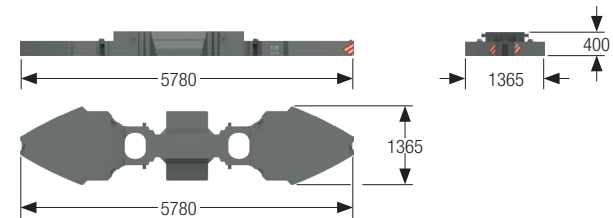

## Basic counterweight slab without tie-down (1x)

Weight	kg	10000
--------	----	-------

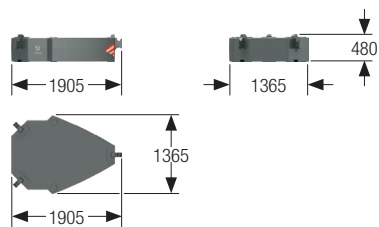

## Counterweight slab (12x)

Weight	kg	5000
--------	----	------

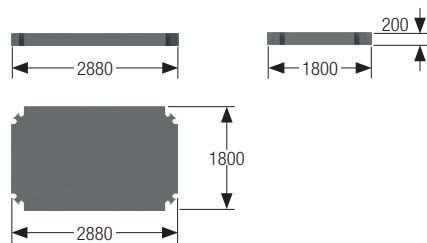

## Carbody counterweight slab (2x)

Weight	kg	8300
--------	----	------

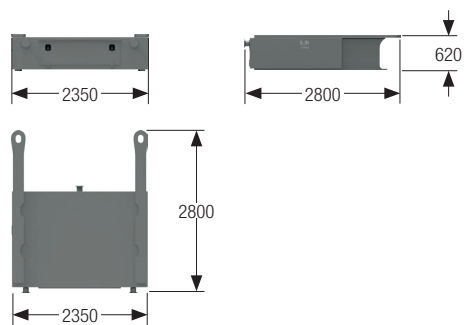

## Carbody counterweight (2x)

Weight	kg	9800
--------	----	------

## Pulley block with additional weights / load hooks

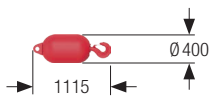
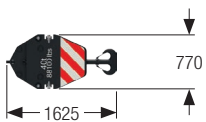
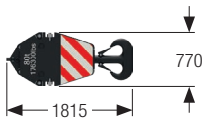
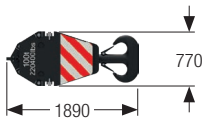
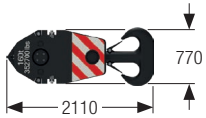
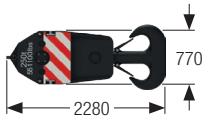

### 250t pulley block – 11 pulleys

Width	mm	1250
Weight	kg	2300 / 3200

### 160t pulley block – 7 pulleys

Width	mm	885
Weight	kg	1500 / 2250 / 3000

### 100t pulley block – 5 pulleys

Width	mm	745
Weight	kg	1300 / 1800 / 2300

### 80t pulley block – 3 pulleys

Width	mm	565
Weight	kg	1000 / 1500 / 2000

### 40t pulley block – 1 pulley

Width	mm	490
Weight	kg	700 / 1100 / 1500

### 12.5t load hook

Weight	kg	600
--------	----	-----

# Self-assembly system

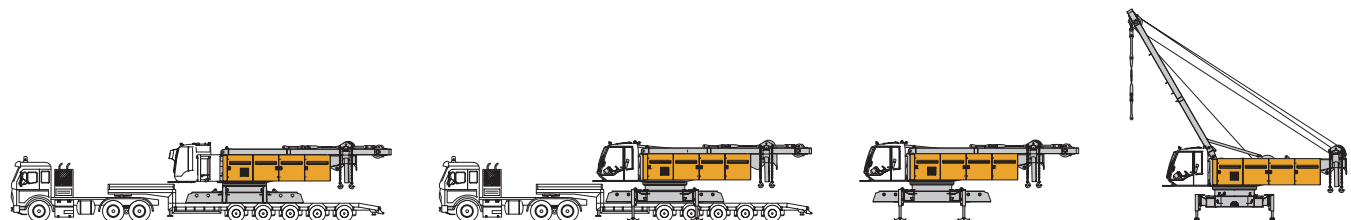

Unloading of basic machine

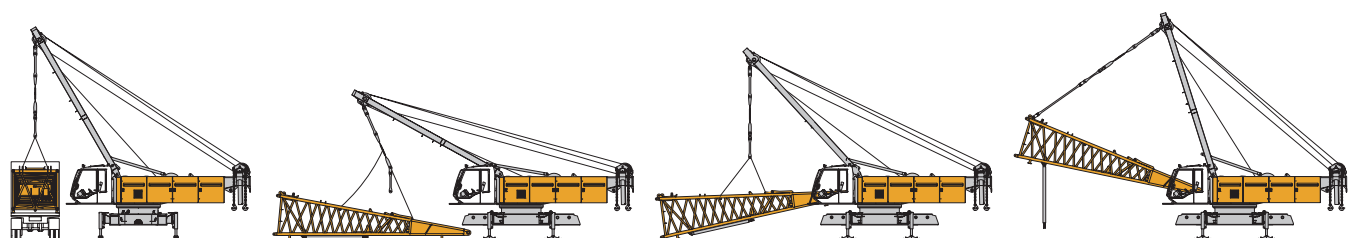

Unloading and assembly of boom foot

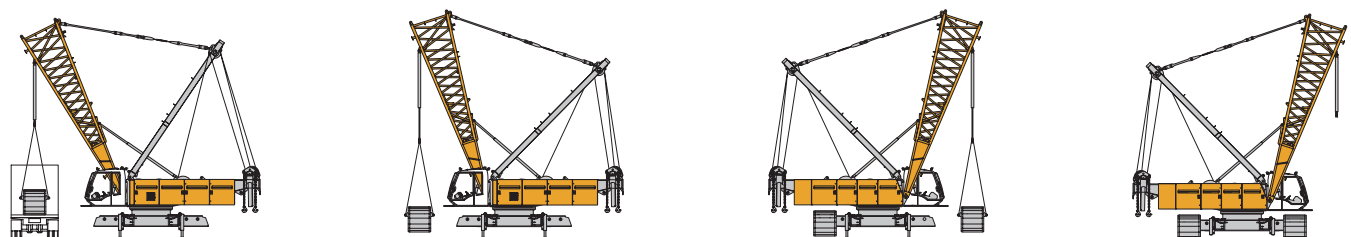

Unloading and assembly of crawler side frames

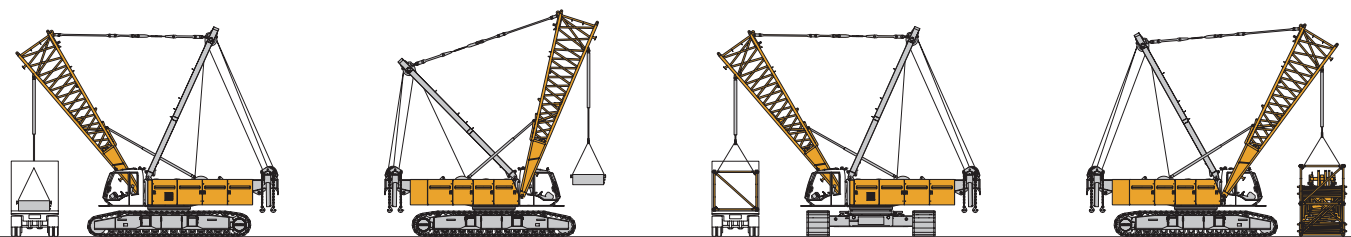

Unloading and assembly of carbody counterweight

Unloading and assembly of boom

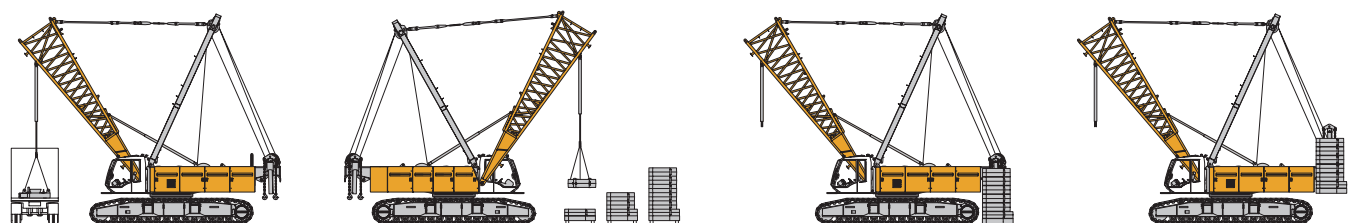

Unloading and assembly of rear counterweight

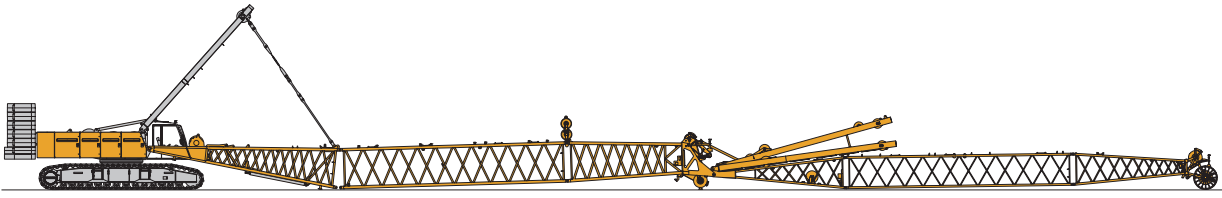

Assembly of boom

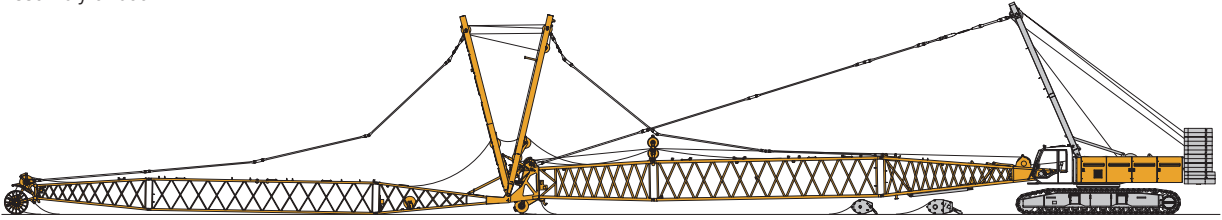

Reeving of hoist and luffing jib ropes

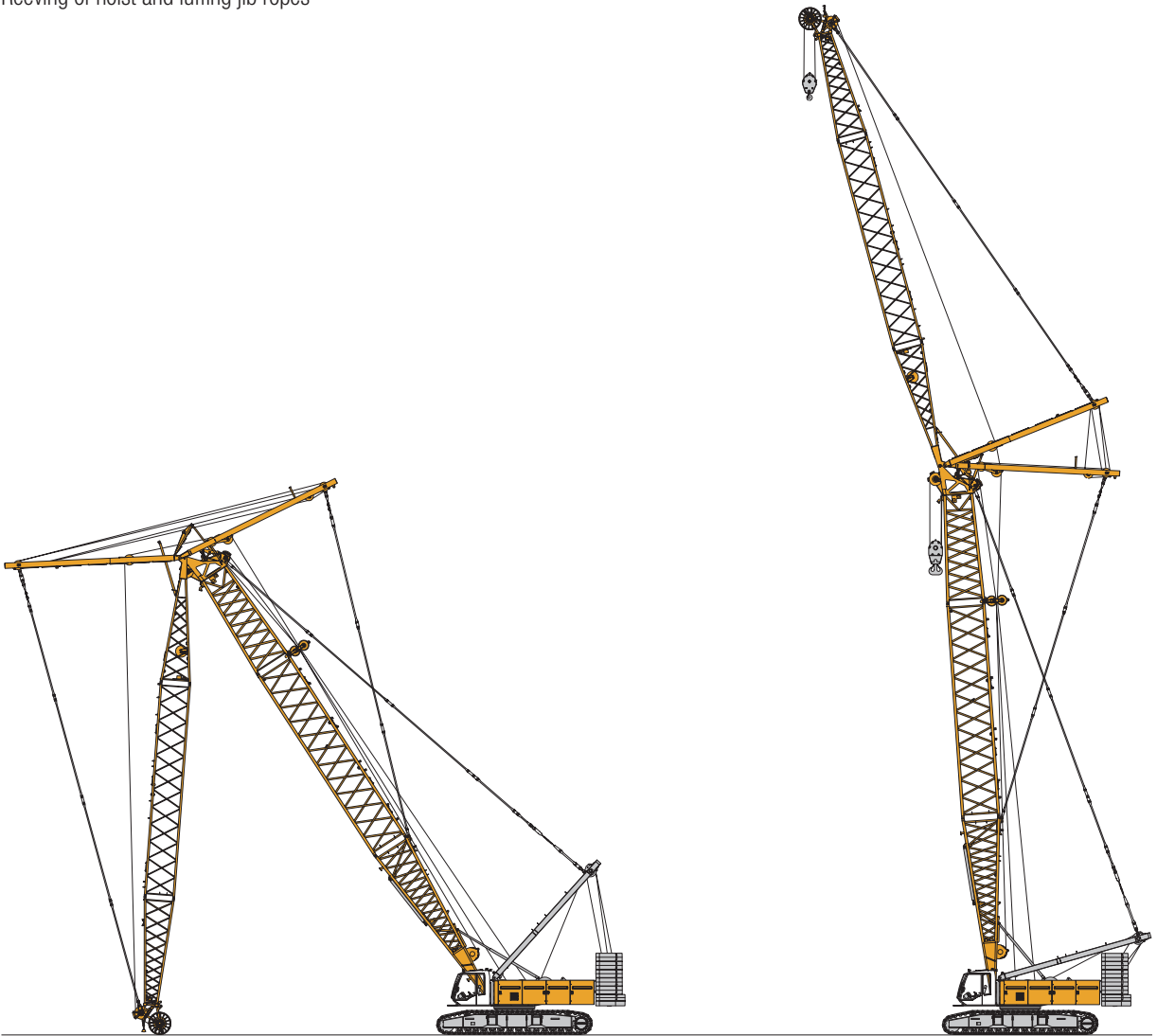

Erecting of main boom and luffing jib

# Boom combinations

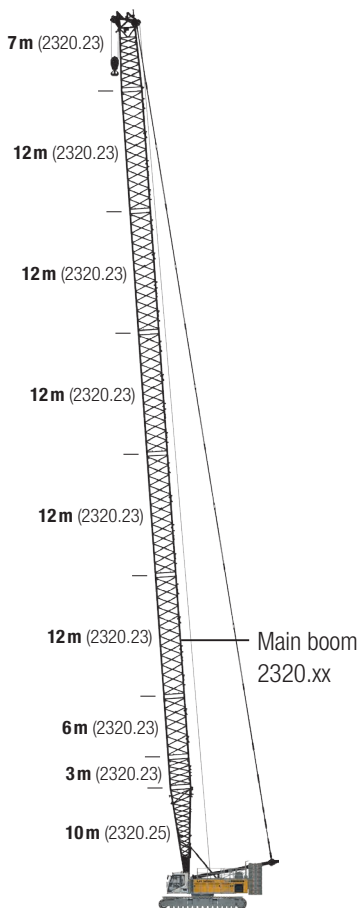

## Main boom

Mode 1

### Max. length

2320.xx	m	86
---------	---	----

Further information on page 18.

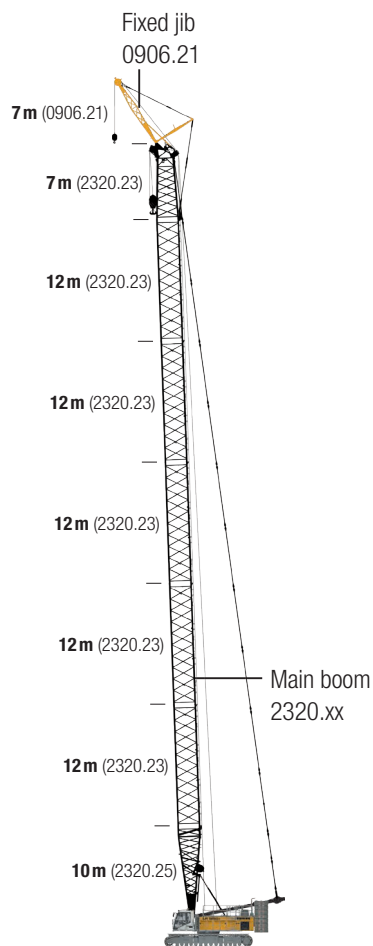

## Main boom + fixed jib

Mode 3

### Max. combination

2320.xx	m	77
0906.21	m	7
Total length	m	84

Further information on page 38.

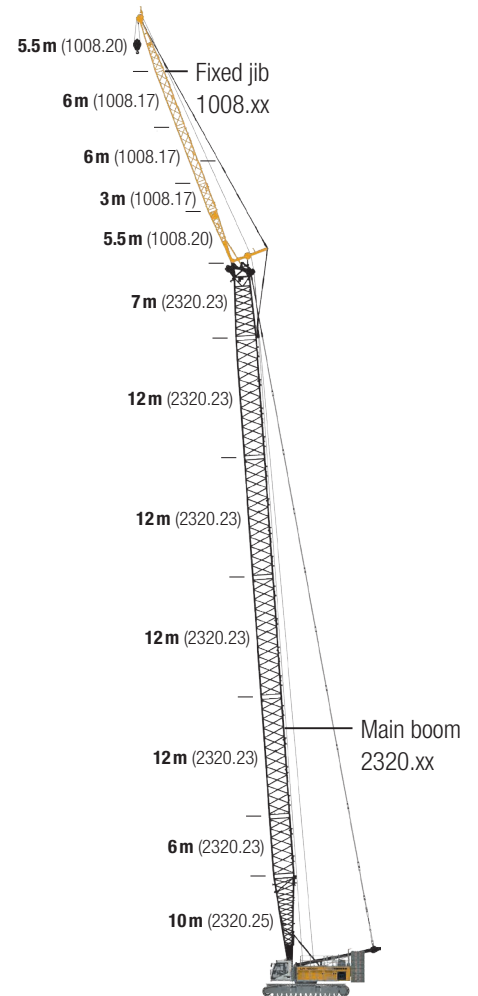

## Main boom + fixed jib

Mode 3

### Max. combination

2320.xx	m	71	74
1008.xx	m	26	17
Total length	m	97	91

Further information on page 32.





# Main boom 2320.xx

Main boom lengths 20-86 m

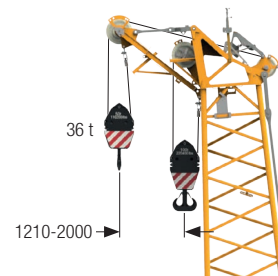
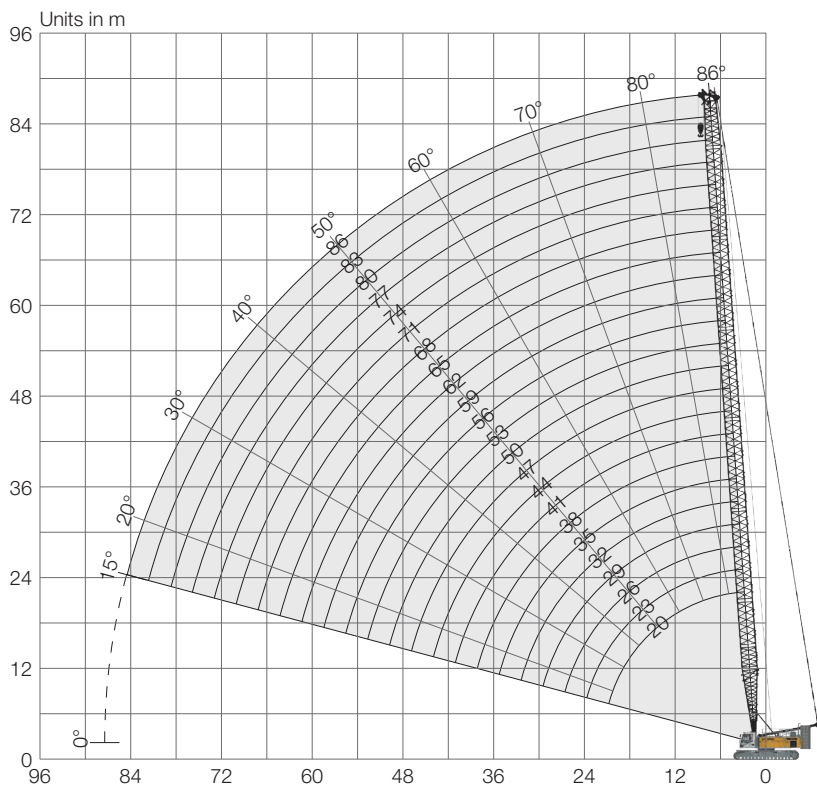

## Auxiliary jib 36 t (option)

The maximum capacity of the auxiliary jib is 36 t. The corresponding load chart is programmed in the LML system.

## Main boom configuration 2320.xx

Boom section	Amount of boom sections												
Boom foot 10 m	1	1	1	1	1	1	1	1	1	1	1	1	1
Boom section 3 m	1		1		1		1		1		1		1
Boom section 6 m		1	1			1	1			1	1		1
Boom section 12 m				1	1	1	1	2	2	2	2	3	
Boom head 7 m	1	1	1	1	1	1	1	1	1	1	1	1	1
<b>Boom length [m]</b>	<b>20</b>	<b>23</b>	<b>26</b>	<b>29</b>	<b>32</b>	<b>35</b>	<b>38</b>	<b>41</b>	<b>44</b>	<b>47</b>	<b>50</b>	<b>53</b>	
Auxiliary jib	✓	✓	✓	✓	✓	✓	✓	✓	✓	✓	✓	✓	✓
Boom foot 10 m	1	1	1	1	1	1	1	1	1	1	1	1	
Boom section 3 m	1		1		1		1		1		1		1
Boom section 6 m		1	1			1	1			1	1		1
Boom section 12 m	3	3	3	4	4	4	4	5	5	5	5	5	
Boom head 7 m	1	1	1	1	1	1	1	1	1	1	1	1	1
<b>Boom length [m]</b>	<b>56</b>	<b>59</b>	<b>62</b>	<b>65</b>	<b>68</b>	<b>71</b>	<b>74</b>	<b>77</b>	<b>80</b>	<b>83</b>	<b>86</b>		
Auxiliary jib	✓	✓	✓	✓	✓	✓	✓	✓	✓	✓	✓	✓	✓

# Load capacities with main boom

## Load capacities in [t] with 82.3t rear counterweight and 36t carbody counterweight

Radius [m]	Boom length [m]												
	20	26	32	38	44	50	56	62	68	74	80	86	
5.8					122.1								
6				143.5	122.1								
7			149.9	136.5	117.5	101.4	86.4	72.1					
8		139.3	132.4	124.5	112.6	96.9	83.4	71.5	59.1	49.8			
9	129.7	122.7	115.9	109.6	103.9	93.0	80.4	68.1	57.7	49.5	41.2	34.0	
12	87.5	87.5	83.8	80.0	76.6	73.4	70.3	61.3	52.9	45.8	39.6	32.7	
18	50.0	50.0	49.9	49.6	49.1	47.3	45.6	43.9	42.3	38.7	34.4	29.2	
20	43.3	43.4	43.3	43.0	42.7	41.9	40.4	38.9	37.5	36.1	32.4	28.2	
22		38.2	38.1	37.8	37.5	37.1	36.2	34.9	33.6	32.3	30.6	26.9	
28			27.4	27.1	26.8	26.4	26.1	25.7	24.9	23.9	22.9	21.9	
34				20.5	20.3	19.9	19.5	19.1	18.7	18.2	17.4	16.5	
38				17.3	17.1	16.7	16.4	15.9	15.5	15.1	14.7	13.8	
40					15.8	15.4	15.0	14.6	14.2	13.8	13.3	12.6	
44					13.4	13.1	12.8	12.4	12.0	11.6	11.2	10.6	
46						12.1	11.9	11.4	11.0	10.6	10.2	9.7	
50						10.4	10.2	9.7	9.3	8.9	8.5	8.0	
55							8.3	8.0	7.6	7.1	6.7	6.2	
60								6.5	6.1	5.7	5.2	4.8	
65									4.8	4.4	4.0	3.5	
70										3.3	2.9	2.5	
75											2.0		

## Load capacities in [t] with 72.3t rear counterweight and 36t carbody counterweight

Radius [m]	Boom length [m]												
	20	26	32	38	44	50	56	62	68	74	80	83	
4.1	219.1												
5	216.9	199.9	173.7										
6	194.3	180.1	165.5	143.5	122.1								
7	164.9	152.4	141.7	132.2	117.5	101.4	86.4	72.1					
8	138.9	129.7	121.6	114.3	107.8	96.9	83.4	71.5	59.1	49.8			
10	104.8	99.5	94.4	89.6	85.3	81.2	77.1	65.7	56.0	48.1	40.7	36.9	
12	80.2	80.1	76.7	73.3	70.1	67.1	64.2	61.3	52.9	45.8	39.6	35.9	
14	64.5	64.5	64.4	61.7	59.2	56.8	54.6	52.4	50.0	43.2	37.6	34.3	
18	45.7	45.7	45.5	45.2	44.7	43.0	41.4	39.8	38.3	36.8	34.4	31.5	
22		34.7	34.6	34.3	34.0	33.7	32.8	31.5	30.3	29.0	27.9	27.3	
26		27.5	27.5	27.2	26.9	26.5	26.2	25.6	24.6	23.5	22.5	22.0	
30			22.4	22.2	21.9	21.5	21.1	20.7	20.3	19.3	18.4	18.0	
34				18.4	18.1	17.7	17.4	17.0	16.6	16.1	15.2	14.8	
36				16.8	16.6	16.2	15.8	15.4	15.0	14.6	13.9	13.5	
38				15.4	15.2	14.8	14.5	14.1	13.7	13.2	12.7	12.3	
44					11.9	11.6	11.2	10.8	10.4	10.0	9.5	9.3	
50						9.1	8.8	8.3	7.9	7.5	7.1	6.9	
55							7.1	6.7	6.3	5.9	5.4	5.2	
60								5.3	4.9	4.5	4.1	3.9	
65									3.8	3.4	2.9	2.7	
70										2.4			



TLT 11962152. Above load charts are for reference only. For actual lift duty please refer to load chart in operator's cabin or manual. Otherwise we recommend you to plan your lifting job using Crane Planner 2.0.

[www.liebherr.com/CranePlanner](http://www.liebherr.com/CranePlanner)

**Crane Planner 2.0**

# Luffing jib 1713.xx

Jib lengths 20-83 m

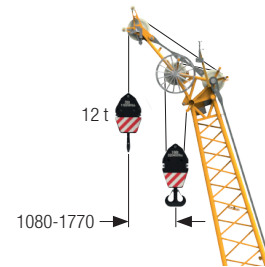
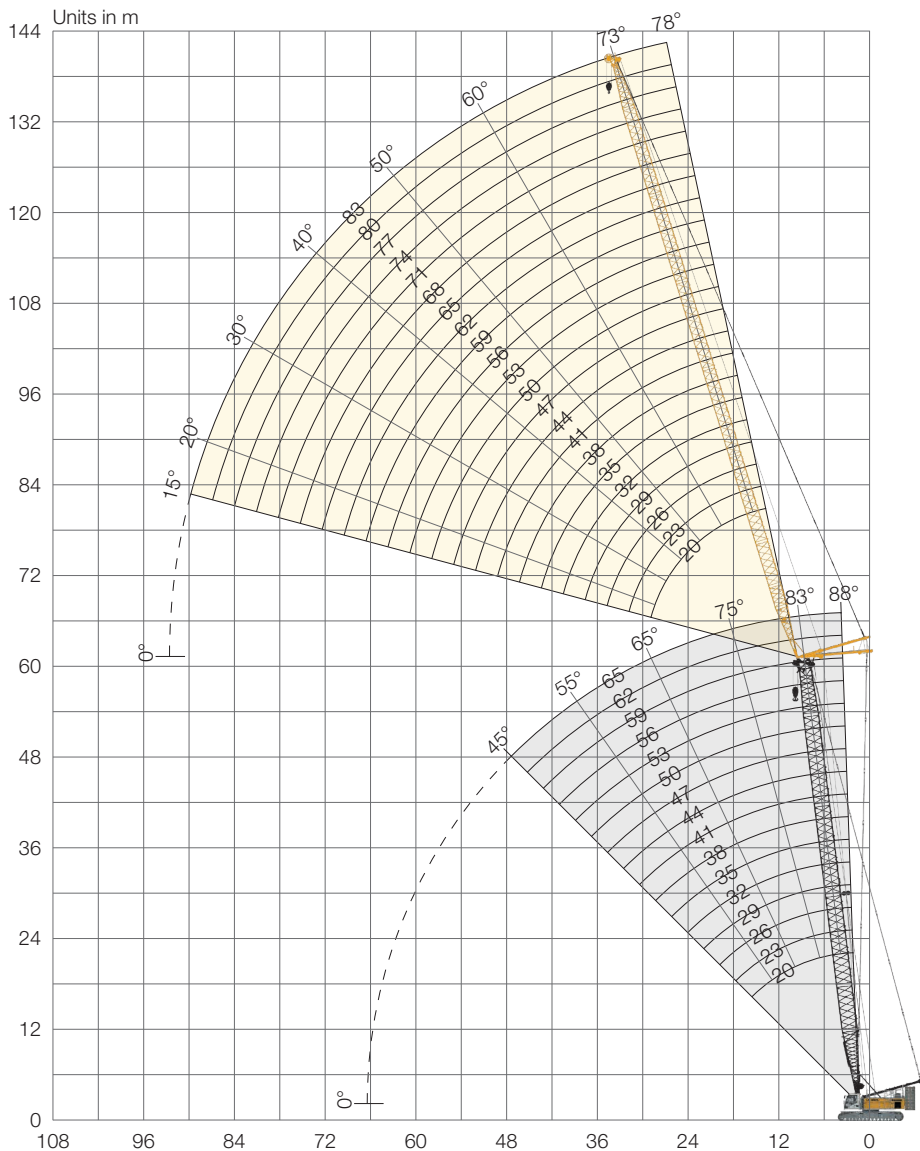

## Auxiliary jib 12 t (option)

The maximum capacity of the auxiliary jib is 12 t.

## Jib configuration 1713.xx

Jib section	Amount of jib sections																						
Jib foot 7 m	1	1	1	1	1	1	1	1	1	1	1	1	1	1	1	1	1	1	1	1			
Jib section 3 m		1		1		1		1		1		1		1		1		1		1			
Jib section 6 m	1	1			1	1			1	1			1	1			1	1		1			
Jib section 12 m			1	1	1	1	1	2	2	2	3	3	3	3	4	4	4	4	5	5			
Jib head 7 m	1	1	1	1	1	1	1	1	1	1	1	1	1	1	1	1	1	1	1	1			
<b>Jib length [m]</b>	<b>20</b>	<b>23</b>	<b>26</b>	<b>29</b>	<b>32</b>	<b>35</b>	<b>38</b>	<b>41</b>	<b>44</b>	<b>47</b>	<b>50</b>	<b>53</b>	<b>56</b>	<b>59</b>	<b>62</b>	<b>65</b>	<b>68</b>	<b>71</b>	<b>74</b>	<b>77</b>	<b>80</b>	<b>83</b>	
Auxiliary jib	✓	✓	✓	✓	✓	✓	✓	✓	✓	✓	✓	✓	✓	✓	✓	✓	✓	✓	✓	✓	✓	✓	✓

For main boom configuration please refer to the table on page 18.

# Load capacities with luffing jib

**Load capacities in [t] with 20m main boom 88°**

Radius [m]	Jib length [m]					
	20	32	44	56	68	83
9	60.0					
11	52.2	46.1				
13	42.1	37.8	30.3			
16	32.1	29.4	26.8	18.8		
18	27.6	25.2	22.8	17.9	12.0	
22	19.7	19.7	18.0	15.7	11.0	6.9
24		17.7	16.2	14.7	10.5	6.7
36			9.9	8.7	7.7	5.4
44			7.5	6.6	5.7	4.7
55				4.7	3.9	3.0
60					3.4	2.4
65					2.8	

82.3t rear counterweight and 36t carbody counterweight

**Load capacities in [t] with 29m main boom 88°**

Radius [m]	Jib length [m]					
	20	32	44	56	68	83
8.1	60.0					
11	55.8	44.3				
14	40.4	36.0	28.4			
16	34.2	31.3	26.7	17.9		
18	29.4	26.6	23.7	17.1		
20	25.6	23.9	21.7	16.3	11.1	
22	22.2	20.9	19.0	15.5	10.5	6.4
32		13.3	12.1	10.9	8.6	5.6
42			8.6	7.5	6.4	4.8
48				6.3	5.3	4.1
60					3.6	2.7
65					3.0	2.2

82.3t rear counterweight and 36t carbody counterweight

**Load capacities in [t] with 41m main boom 88°**

Radius [m]	Jib length [m]					
	20	32	44	56	68	83
8.6	60.0					
11	53.6	39.2				
14	42.2	35.3	25.6			
16	35.5	32.0	24.5	16.4		
20	26.5	24.0	21.5	15.4	10.2	
22	23.2	21.5	19.3	14.6	9.9	5.8
30		14.7	13.3	11.7	8.7	5.4
36			10.6	9.4	7.9	5.0
48				6.4	5.4	4.0
55				5.2	4.3	3.3
60					3.7	2.8
70					2.4	

82.3t rear counterweight and 36t carbody counterweight

**Load capacities in [t] with 50m main boom 88°**

Radius [m]	Jib length [m]					
	20	32	44	56	68	83
8.9	50.8					
12	44.9	34.6				
14	40.5	32.9	22.8			
18	31.1	27.0	21.1	14.5		
20	27.0	24.4	20.1	13.9	9.4	
22	23.9	21.8	18.7	13.3	9.2	5.2
30		14.9	13.2	11.3	8.2	5.0
36			10.7	9.2	7.6	4.8
46			7.7	6.7	5.7	4.1
55				5.1	4.4	3.3
65					3.2	2.4
70					2.5	

82.3t rear counterweight and 36t carbody counterweight

**Load capacities in [t] with 62m main boom 88°**

Radius [m]	Jib length [m]					
	20	32	44	56	62	65
9.3	36.4					
12	34.3	25.2				
16	30.1	23.3	17.4			
18	27.7	22.2	16.8	12.0		
20	24.8	21.3	16.1	11.6	9.5	8.7
26		16.7	14.7	10.5	8.9	8.2
34		12.8	11.5	9.6	8.5	7.7
36			10.8	9.0	8.3	7.6
46			7.8	6.7	6.3	5.9
55				5.2	4.8	4.6
60					4.2	4.0
65						3.4

82.3t rear counterweight and 36t carbody counterweight

TLT 11962152. Above load charts are for reference only. For actual lift duty please refer to load chart in operator's cabin or manual. Otherwise we recommend you to plan your lifting job using Crane Planner 2.0.



[www.liebherr.com/CranePlanner](http://www.liebherr.com/CranePlanner)

**Crane Planner 2.0**

# Load capacities with luffing jib

## Load capacities in [t] with 20m main boom 83°

Radius [m]	Jib length [m]					
	20	32	44	56	68	83
11.3	59.9					
16	36.9	33.5				
20	27.2	24.5	22.1			
22	23.8	21.7	19.6	16.3		
24	20.4	19.3	17.4	15.7		
26		17.6	15.8	14.3	10.2	
28		16.0	14.4	13.0	10.0	
30		14.7	13.1	11.8	9.7	6.1
38			9.8	8.6	7.6	5.5
55				5.1	4.2	3.1
60					3.6	2.6
70					2.5	

82.3t rear counterweight and 36t carbody counterweight

## Load capacities in [t] with 29m main boom 83°

Radius [m]	Jib length [m]					
	20	32	44	56	68	83
12.4	59.9					
16	42.8	36.4				
20	30.7	27.6	24.3			
24	23.7	21.6	19.6	15.5		
26		19.2	17.4	14.8		
28		17.5	15.9	14.2	9.8	
30		16.0	14.5	12.9	9.5	
36		12.5	11.4	10.1	8.4	5.5
40			10.0	8.7	7.6	5.2
48			7.6	6.8	5.7	4.5
50				6.4	5.3	4.2
70					2.8	2.0

82.3t rear counterweight and 36t carbody counterweight

## Load capacities in [t] with 41m main boom 83°

Radius [m]	Jib length [m]					
	20	32	44	56	68	83
13.8	54.7					
18	40.4	34.2				
22	29.6	26.4	22.5			
26	23.0	20.9	18.8	14.3		
28		18.8	16.9	13.9	9.2	
34		14.6	13.0	11.6	8.7	5.5
40			10.5	9.2	7.9	5.1
50			7.6	6.7	5.6	4.2
60				5.0	4.2	3.2
65					3.6	2.7
70					3.0	2.2
75						

82.3t rear counterweight and 36t carbody counterweight

## Load capacities in [t] with 50m main boom 83°

Radius [m]	Jib length [m]					
	20	32	44	56	68	83
14.9	44.2					
20	35.9	30.1				
22	32.0	27.6	20.2			
24	27.8	24.5	19.8			
26	24.6	22.2	19.0	13.0		
28	21.6	19.6	17.3	12.8		
30		17.9	16.0	12.5	8.7	
34		15.1	13.4	11.4	8.3	5.0
40			10.8	9.3	7.7	4.8
48			8.4	7.2	6.2	4.3
55				5.9	5.0	3.7
70					3.2	2.3

82.3t rear counterweight and 36t carbody counterweight

## Load capacities in [t] with 62m main boom 83°

Radius [m]	Jib length [m]					
	20	32	44	56	62	65
16.4	32.2					
20	29.7	23.1				
24	26.5	21.5	16.2			
28	22.8	19.4	15.8	11.3		
30		18.3	15.5	11.2	9.4	8.4
36		14.6	12.9	10.7	8.9	8.1
42			10.6	9.0	8.3	7.7
48			8.8	7.5	6.9	6.5
55				6.1	5.6	5.4
60				5.3	4.9	4.6
65					4.3	4.0
70					3.3	3.5

82.3t rear counterweight and 36t carbody counterweight

TLT 11962152. Above load charts are for reference only. For actual lift duty please refer to load chart in operator's cabin or manual. Otherwise we recommend you to plan your lifting job using Crane Planner 2.0.



[www.liebherr.com/CranePlanner](http://www.liebherr.com/CranePlanner)

**Crane Planner 2.0**

# Load capacities with luffing jib

## Load capacities in [t] with 20m main boom 75°

Radius [m]	Jib length [m]					
	20	32	44	56	68	83
16.7	44.4					
22	28.8	25.5				
28		18.0	16.4			
32		14.9	13.6	11.7		
38		12.0	10.7	9.5	8.1	
40			9.9	8.8	7.6	
44			8.6	7.7	6.6	5.1
50			7.2	6.2	5.2	4.2
55				5.4	4.4	3.5
60				4.7	3.7	2.8
65					3.2	2.3
70					2.7	

82.3t rear counterweight and 36t carbody counterweight

## Load capacities in [t] with 29m main boom 75°

Radius [m]	Jib length [m]					
	20	32	44	56	68	83
19	45.4					
24	30.6	24.0				
30		19.0	17.3			
36		14.5	13.1	11.9		
40		12.5	11.3	10.1	8.5	
42			10.5	9.3	8.1	
46			9.1	8.1	7.0	4.9
55				6.0	5.1	4.1
60				5.3	4.3	3.3
65					3.7	2.8
70					3.2	2.3
75					2.7	

82.3t rear counterweight and 36t carbody counterweight

## Load capacities in [t] with 41m main boom 75°

Radius [m]	Jib length [m]					
	20	32	44	56	68	83
22.1	35.7					
28	28.1	25.6				
30	25.5	22.9				
32	22.6	20.2				
34		18.3	16.5			
36		16.7	15.0			
38		15.2	13.8	12.0		
44		12.3	11.0	9.7	8.1	
50			9.0	7.9	6.8	4.6
55			7.8	6.7	5.7	4.3
65				5.1	4.1	3.2
75					3.1	2.1

82.3t rear counterweight and 36t carbody counterweight

## Load capacities in [t] with 50m main boom 75°

Radius [m]	Jib length [m]					
	20	32	44	56	68	83
24.4	29.6					
30	24.3	22.7				
34	21.2	20.1				
36		18.4	16.5			
40		15.4	13.8	11.5		
46		12.4	11.0	9.6	7.7	
48			10.2	8.8	7.6	
55			8.3	7.0	6.1	4.3
60				6.0	5.2	4.0
70				4.3	3.8	2.9
75					3.3	2.4
80					2.8	

82.3t rear counterweight and 36t carbody counterweight

## Load capacities in [t] with 62m main boom 75°

Radius [m]	Jib length [m]					
	20	32	44	56	62	65
27.5	23.2					
32	20.0					
34	18.9	17.5				
38	16.9	15.6	14.4			
42		14.1	13.0			
44		13.4	12.3	10.6		
46		12.8	11.7	10.5	8.6	
48		12.3	11.2	9.7	8.6	7.7
50			10.6	9.1	8.3	7.6
65				5.7	5.3	5.0
75					4.0	3.8
80						3.3

82.3t rear counterweight and 36t carbody counterweight

TLT 11962152. Above load charts are for reference only. For actual lift duty please refer to load chart in operator's cabin or manual. Otherwise we recommend you to plan your lifting job using Crane Planner 2.0.



[www.liebherr.com/CranePlanner](http://www.liebherr.com/CranePlanner)

**Crane Planner 2.0**

# Load capacities with luffing jib

**Load capacities in [t] with 20m main boom 65°**

Radius [m]	Jib length [m]					
	20	32	44	56	68	83
24	31.3					
26	26.9					
30	21.2	18.9				
38		13.4	12.1			
40		12.5	11.0			
42		11.6	10.3			
44			9.5	8.3		
48			8.4	7.3		
50			8.0	6.9		
60				5.1	4.2	3.0
70					3.0	2.1
75					2.6	

82.3t rear counterweight and 36t carbody counterweight

**Load capacities in [t] with 32m main boom 65°**

Radius [m]	Jib length [m]					
	20	32	44	56	68	83
27.9	24.0					
36		18.9				
38		17.1				
42		14.4	12.7			
44		13.5	12.1			
46		12.6	11.2			
50			9.7	8.6		
55			8.4	7.3		
60				6.2	5.2	
65				5.4	4.4	3.3
75					3.3	2.4
80					2.9	

82.3t rear counterweight and 36t carbody counterweight

**Load capacities in [t] with 44m main boom 65°**

Radius [m]	Jib length [m]					
	20	32	44	56	68	83
33	20.2					
34	19.5					
40	16.0	15.4				
46		12.9				
48		12.2	11.6			
55			9.7	8.5		
65				6.2	5.2	
70				5.5	4.5	3.3
75				4.8	3.8	2.8
80					3.3	2.3
85					2.9	
90						

82.3t rear counterweight and 36t carbody counterweight

**Load capacities in [t] with 56m main boom 65°**

Radius [m]	Jib length [m]					
	20	32	44	56	68	83
38.1	14.8					
44	12.4					
46	11.7	11.0				
48		10.5				
55		8.8	8.0			
60			7.1	6.2		
65			6.4	5.5		
70				4.9	4.0	
75				4.4	3.5	2.4
80				3.9	3.1	2.0
85					2.7	
90					2.4	

82.3t rear counterweight and 36t carbody counterweight

**Load capacities in [t] with 62m main boom 65°**

Radius [m]	Jib length [m]					
	20	32	44	56	62	65
40.6	12.3					
44	11.3					
46	10.8					
48	10.2	9.2				
50		8.8				
55		7.8	6.8			
60		7.0	6.1			
65			5.4	4.5	4.1	
70			4.9	4.0	3.6	3.3
75				3.5	3.1	2.9
80				3.1	2.7	2.5
85					2.4	2.1

82.3t rear counterweight and 36t carbody counterweight

TLT 11962152. Above load charts are for reference only. For actual lift duty please refer to load chart in operator's cabin or manual. Otherwise we recommend you to plan your lifting job using Crane Planner 2.0.



[www.liebherr.com/CranePlanner](http://www.liebherr.com/CranePlanner)

**Crane Planner 2.0**





# Luffing jib 1916.xx

Jib lengths 20-95 m

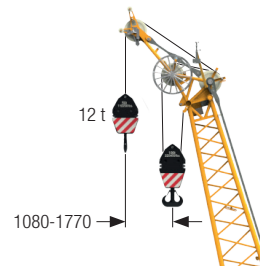
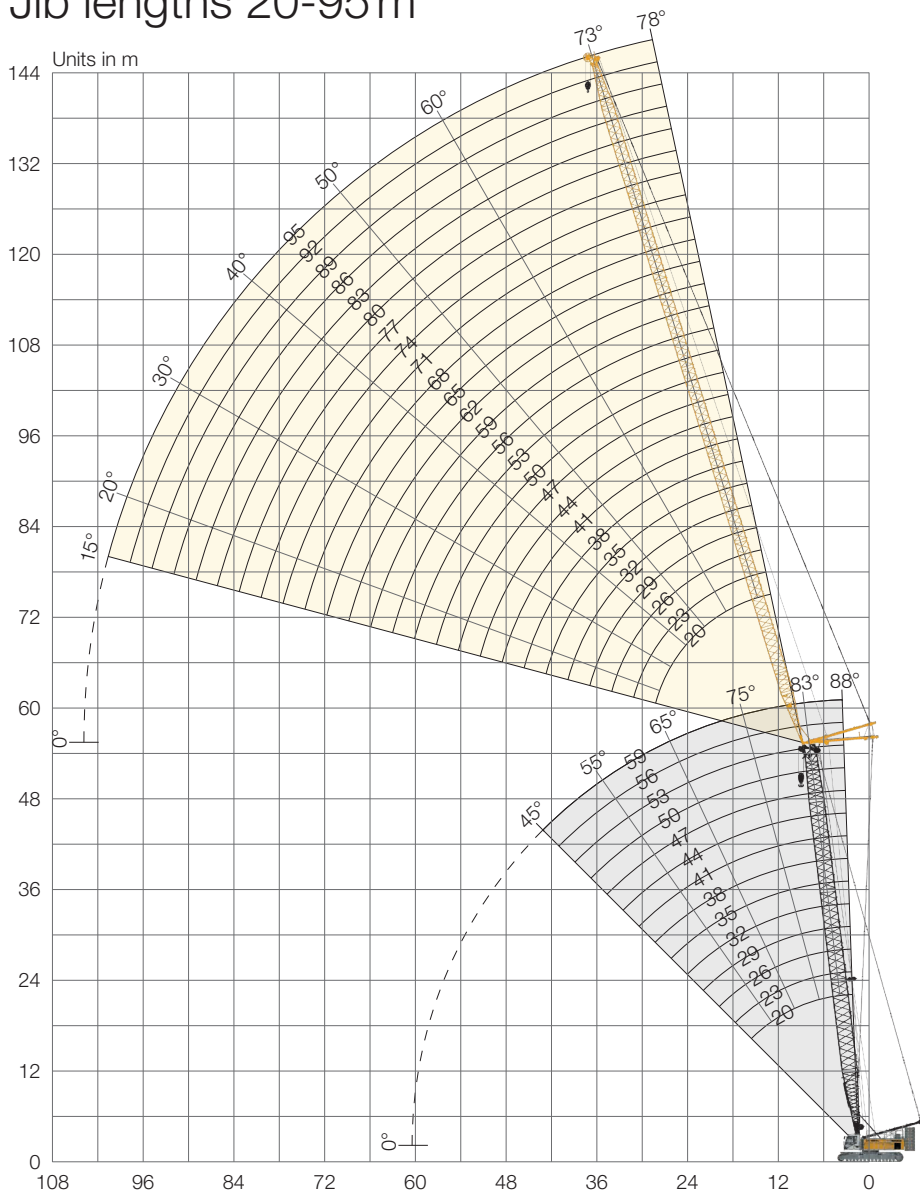

## Auxiliary jib 12 t (option)

The maximum capacity of the auxiliary jib is 12 t.

## Jib configuration 1916.xx

Jib section	Amount of jib sections																										
Jib foot 7 m	1	1	1	1	1	1	1	1	1	1	1	1	1	1	1	1	1	1	1	1	1	1	1	1			
Jib section 3 m		1		1		1		1		1		1		1		1		1		1		1		1			
Jib section 6 m	1	1			1	1			1	1			1	1			1	1			1	1		1			
Jib section 12 m			1	1	1	1	1	2	2	2	3	3	3	3	4	4	4	4	5	5	5	5	6	6			
Jib head 7 m	1	1	1	1	1	1	1	1	1	1	1	1	1	1	1	1	1	1	1	1	1	1	1	1			
<b>Jib length [m]</b>	<b>20</b>	<b>23</b>	<b>26</b>	<b>29</b>	<b>32</b>	<b>35</b>	<b>38</b>	<b>41</b>	<b>44</b>	<b>47</b>	<b>50</b>	<b>53</b>	<b>56</b>	<b>59</b>	<b>62</b>	<b>65</b>	<b>68</b>	<b>71</b>	<b>74</b>	<b>77</b>	<b>80</b>	<b>83</b>	<b>86</b>	<b>89</b>	<b>92</b>	<b>95</b>	
Auxiliary jib	✓	✓	✓	✓	✓	✓	✓	✓	✓	✓	✓	✓	✓	✓	✓	✓	✓	✓	✓	✓	✓	✓	✓	✓	✓	✓	✓

For main boom configuration please refer to the table on page 18.

# Load capacities with luffing jib

**Load capacities in [t] with 20m main boom 88°**

Radius [m]	Jib length [m]					
	20	35	50	65	80	95
9	70.7					
11	70.7	49.6				
12	69.8	48.1				
16	47.7	40.2	28.5			
18	39.9	34.6	27.0	16.7		
22	28.4	26.9	23.7	15.4	9.7	
24		23.7	21.3	14.7	9.4	5.3
32		16.5	15.0	12.8	8.6	5.1
38			12.1	10.6	8.0	4.8
46			9.5	8.0	6.7	4.3
55				6.1	5.1	3.5
75					2.5	

82.3t rear counterweight and 36t carbody counterweight

**Load capacities in [t] with 29m main boom 88°**

Radius [m]	Jib length [m]					
	20	35	50	65	80	95
8.1	70.7					
12	66.1	45.4				
16	49.2	39.2	26.3			
18	42.3	36.0	25.1	15.2		
22	32.0	29.9	23.0	14.5	8.7	
24		26.5	21.9	14.0	8.5	4.6
32		19.2	17.4	12.7	8.2	4.6
38			14.5	11.6	7.7	4.5
44			12.2	10.4	7.2	4.2
65				6.1	4.9	3.0
75					3.7	2.2
80					3.1	

82.3t rear counterweight and 36t carbody counterweight

**Load capacities in [t] with 41m main boom 88°**

Radius [m]	Jib length [m]					
	20	35	50	65	80	95
8.6	61.2					
12	55.6	38.7				
16	42.4	35.2	23.0			
18	37.0	32.1	22.4	13.2		
22	28.8	26.1	20.8	12.8	7.7	
24		23.3	19.5	12.6	7.6	
34		16.3	14.4	11.6	7.4	4.0
40			12.2	10.1	7.0	4.0
50			9.6	7.8	6.0	3.7
55				6.9	5.6	3.3
70					3.6	2.3
80					2.6	

82.3t rear counterweight and 36t carbody counterweight

**Load capacities in [t] with 50m main boom 88°**

Radius [m]	Jib length [m]					
	20	35	50	65	80	95
8.9	50.8					
12	46.1	32.0				
16	37.2	29.7	20.1			
20	29.1	25.2	18.8	11.6		
22	26.1	23.1	18.3	11.3	6.9	
24		20.9	17.3	11.3	6.8	
26		19.1	16.3	11.2	6.8	3.5
40			11.1	9.0	6.6	3.5
50			8.8	6.9	5.5	3.4
65				4.8	3.6	2.4
70					3.1	
80					2.2	

82.3t rear counterweight and 36t carbody counterweight

**Load capacities in [t] with 56m main boom 88°**

Radius [m]	Jib length [m]					
	20	35	50	65	71	74
9.1	43.1					
13	38.8	27.1				
16	33.8	25.3	17.4			
20	27.0	22.4	16.1	10.6	8.7	
26		17.5	14.3	10.0	8.4	7.6
28		16.3	13.8	9.9	8.3	7.6
36		13.0	11.1	9.3	8.0	7.5
38		12.4	10.5	8.8	8.0	7.4
50			7.9	6.4	5.9	5.6
65				4.4	3.9	3.7
70					3.4	3.2
75						2.7

82.3t rear counterweight and 36t carbody counterweight

TLT 11962152. Above load charts are for reference only. For actual lift duty please refer to load chart in operator's cabin or manual. Otherwise we recommend you to plan your lifting job using Crane Planner 2.0.



[www.liebherr.com/CranePlanner](http://www.liebherr.com/CranePlanner)

**Crane Planner 2.0**

# Load capacities with luffing jib

**Load capacities in [t] with 20m main boom 83°**

Radius [m]	Jib length [m]					
	20	35	50	65	80	95
11.3	70.7					
16	58.3	42.7				
22	34.0	32.7	25.0			
26		24.4	22.4	14.6		
30		20.1	20.1	13.9	9.0	
32		18.5	18.0	13.5	8.8	
34		17.2	16.2	13.2	8.6	5.1
40			12.9	11.3	8.0	4.8
55				7.0	6.4	3.8
65				5.1	4.4	3.1
75					3.1	2.0
80					2.4	

82.3t rear counterweight and 36t carbody counterweight

**Load capacities in [t] with 29m main boom 83°**

Radius [m]	Jib length [m]					
	20	35	50	65	80	95
12.4	70.7					
18	51.1	39.5				
22	39.5	34.3	23.7			
26		29.9	22.1	14.0		
30		26.0	21.2	13.5	8.5	
36		20.7	19.4	12.7	8.1	4.6
42			16.4	11.9	7.6	4.5
48			13.5	11.2	7.1	4.1
50			12.8	10.7	7.0	4.1
60				9.0	6.5	3.4
65				7.8	6.2	3.2
85						2.0

82.3t rear counterweight and 36t carbody counterweight

**Load capacities in [t] with 41 m main boom 83°**

Radius [m]	Jib length [m]					
	20	35	50	65	80	95
13.8	55.4					
20	42.5	33.8				
26	29.6	27.9	20.4			
28		25.7	19.9	12.5		
32		22.2	19.2	12.4	7.5	
40		16.9	16.2	11.5	7.3	4.0
44			14.2	11.0	7.1	4.0
60				8.1	6.1	3.3
65				7.2	5.6	3.1
70				6.2	5.2	2.8
75					4.7	2.5
85					3.1	

82.3t rear counterweight and 36t carbody counterweight

**Load capacities in [t] with 50m main boom 83°**

Radius [m]	Jib length [m]					
	20	35	50	65	80	95
14.9	43.9					
20	37.7	28.7				
24	30.7	26.2	18.5			
30		21.8	17.9	11.1		
34		19.0	17.0	11.0	6.8	
38		16.7	15.2	10.8	6.8	3.5
44			13.0	10.2	6.7	3.5
55			9.8	8.2	6.1	3.5
60				7.2	5.8	3.2
70				5.6	4.6	2.7
75					4.1	2.3
85					2.9	

82.3t rear counterweight and 36t carbody counterweight

**Load capacities in [t] with 56m main boom 83°**

Radius [m]	Jib length [m]					
	20	35	50	65	71	74
15.7	37.4					
22	31.7	23.9				
26	26.4	22.1	16.0			
28	24.3	21.0	15.9			
30		19.9	15.6	10.1		
32		18.9	15.3	10.1	8.3	7.6
40		14.7	13.0	10.0	8.3	7.6
44			11.7	9.5	8.2	7.6
60				6.7	6.3	6.2
65				6.0	5.5	5.4
75					4.2	4.1
80						3.5

82.3t rear counterweight and 36t carbody counterweight

TLT 11962152. Above load charts are for reference only. For actual lift duty please refer to load chart in operator's cabin or manual. Otherwise we recommend you to plan your lifting job using Crane Planner 2.0.



[www.liebherr.com/CranePlanner](http://www.liebherr.com/CranePlanner)

**Crane Planner 2.0**

# Load capacities with luffing jib

**Load capacities in [t] with 20m main boom 75°**

Radius [m]	Jib length [m]					
	20	35	50	65	80	95
16.7	56.4					
24	36.3	34.4				
28		28.5				
30		25.3	22.6			
36		18.4	19.4	13.2		
42		12.1	14.8	12.4	8.0	
44			13.6	12.0	7.9	
50			10.9	10.9	7.4	4.3
55			9.2	8.8	7.0	4.0
60				7.1	6.6	3.7
75					3.9	2.7
85					2.4	2.1

82.3t rear counterweight and 36t carbody counterweight

**Load capacities in [t] with 29m main boom 75°**

Radius [m]	Jib length [m]					
	20	35	50	65	80	95
19	45.7					
26	32.0	30.8				
28	29.2	28.6				
32		24.2	21.5			
36		21.0	20.3			
38		19.6	19.0	12.7		
44		16.3	15.7	12.2		
46			14.8	12.0	7.5	
55			11.7	11.0	6.9	3.9
70				7.6	6.3	3.1
85					4.8	2.3
90						2.1

82.3t rear counterweight and 36t carbody counterweight

**Load capacities in [t] with 41 m main boom 75°**

Radius [m]	Jib length [m]					
	20	35	50	65	80	95
22.1	35.2					
30	25.5	23.9				
32	23.6	22.3				
36		19.8	18.2			
42		16.3	15.4	11.8		
48			13.1	11.4	7.1	
55			10.9	9.9	6.7	3.7
60			9.6	8.9	6.5	3.6
65				7.9	6.3	3.3
80					4.8	2.6
85					4.2	2.4
90					3.7	2.2

82.3t rear counterweight and 36t carbody counterweight

**Load capacities in [t] with 50m main boom 75°**

Radius [m]	Jib length [m]					
	20	35	50	65	80	95
24.4	29.0					
32	22.2	20.3				
34	20.9	19.0				
38		16.9	15.5			
44		14.5	13.1	10.8		
48		12.9	11.9	10.5		
50			11.3	10.0	6.6	
60			9.0	7.8	6.3	3.4
65				7.0	5.8	3.2
75				5.6	4.5	2.8
85					3.5	2.3
90					3.0	

82.3t rear counterweight and 36t carbody counterweight

**Load capacities in [t] with 56m main boom 75°**

Radius [m]	Jib length [m]					
	20	35	50	65	71	74
26	25.6					
34	19.6	17.7				
36	18.5	16.7				
40		14.9	13.5			
46		12.8	11.6	10.1		
48		12.2	11.0	9.6	8.3	
55			9.3	8.0	7.5	7.3
60			8.3	7.1	6.6	6.4
65			7.5	6.3	5.8	5.6
70				5.6	5.1	5.0
80				4.5	4.0	3.8
85					3.5	3.4

82.3t rear counterweight and 36t carbody counterweight

TLT 11962152. Above load charts are for reference only. For actual lift duty please refer to load chart in operator's cabin or manual. Otherwise we recommend you to plan your lifting job using Crane Planner 2.0.



[www.liebherr.com/CranePlanner](http://www.liebherr.com/CranePlanner)

**Crane Planner 2.0**

# Load capacities with luffing jib

## Load capacities in [t] with 20m main boom 65°

Radius [m]	Jib length [m]					
	20	35	50	65	80	95
24	34.8					
30	26.5					
36		20.6				
38		19.3				
44		16.0	15.4			
50			13.0	11.8		
55			11.5	10.7		
60				9.4	6.9	
70				6.6	6.2	3.2
75					5.8	2.9
85					3.8	2.4
90						2.1

82.3t rear counterweight and 36t carbody counterweight

## Load capacities in [t] with 29m main boom 65°

Radius [m]	Jib length [m]					
	20	35	50	65	80	95
28	27.3					
32	23.2					
36		19.4				
44		15.0	14.4			
48		13.4	12.8			
60			9.4	8.6		
65				7.6	6.5	
70				6.7	6.0	3.2
75				6.0	5.3	3.0
80					4.6	2.8
90					3.5	2.3
95						2.1

82.3t rear counterweight and 36t carbody counterweight

## Load capacities in [t] with 41 m main boom 65°

Radius [m]	Jib length [m]					
	20	35	50	65	80	95
31.7	21.3					
34	19.5					
42		14.2				
48		11.9				
50		11.3	10.6			
60			8.1	7.2		
65			7.2	6.3		
70				5.6	4.5	
75				4.9	3.9	2.7
80				4.3	3.4	2.3
85					2.9	
95					2.1	

82.3t rear counterweight and 36t carbody counterweight

## Load capacities in [t] with 50m main boom 65°

Radius [m]	Jib length [m]					
	20	35	50	65	80	83
35.5	16.7					
36	16.5					
38	15.4					
46		11.1				
50		10.0				
55		8.8	7.8			
60			6.9			
65			6.2	4.9		
70			5.5	4.3	3.2	
75				3.8	2.7	2.4
80				3.3	2.2	
85				2.9		

82.3t rear counterweight and 36t carbody counterweight

## Load capacities in [t] with 56m main boom 65°

Radius [m]	Jib length [m]					
	20	35	50	65	71	74
38.1	13.9					
40	13.2					
42	12.5					
46	11.1					
48		9.3				
50		8.9				
60		7.0	5.9			
65			5.2	3.9		
70			4.6	3.4	2.9	2.8
75			4.1	2.9	2.4	2.3
80				2.5	2.0	
85				2.1		

82.3t rear counterweight and 36t carbody counterweight

TLT 11962152. Above load charts are for reference only. For actual lift duty please refer to load chart in operator's cabin or manual. Otherwise we recommend you to plan your lifting job using Crane Planner 2.0.



[www.liebherr.com/CranePlanner](http://www.liebherr.com/CranePlanner)

**Crane Planner 2.0**



# Fixed jib 1008.xx

Jib lengths 11-26 m

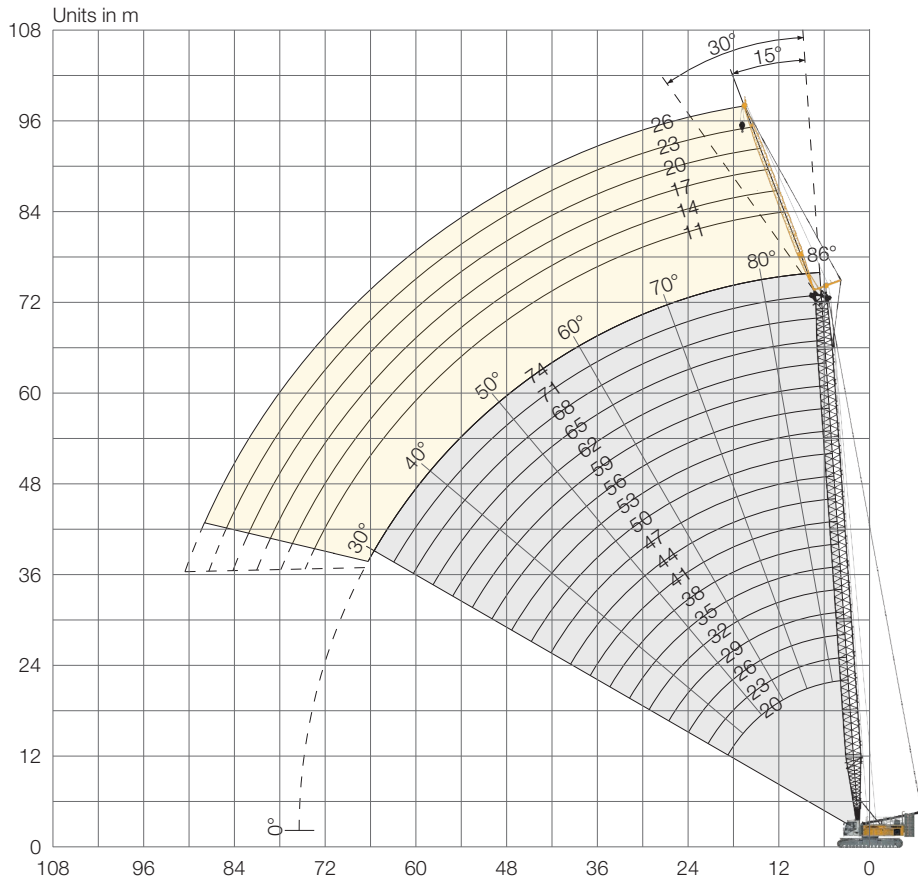

## Jib configuration 1008.xx

Jib section	Amount of jib sections					
Jib foot 5.5 m	1	1	1	1	1	1
Jib section 3 m		1		1		1
Jib section 6 m			1	1	2	2
Jib head 5.5 m	1	1	1	1	1	1
<b>Jib length [m]</b>	<b>11</b>	<b>14</b>	<b>17</b>	<b>20</b>	<b>23</b>	<b>26</b>

For main boom configuration please refer to the table on page 18.



## Load capacities with fixed jib 15°

### Load capacities in [t] with 20m main boom

Radius [m]	Jib length [m]			
	11	14	20	26
9	35.9			
10	35.9	34.1		
11	35.9	33.3	27.4	
12	35.9	32.6	26.4	19.7
16	35.8	29.8	23.1	17.3
22	29.9	25.3	18.5	14.3
28	24.0	20.7	14.8	11.7
30	23.4	19.5	13.8	11.1
32		18.3	13.0	10.5
36			12.1	9.4
38			11.5	9.0
44				8.0

82.3t rear counterweight and 36t carbody counterweight

### Load capacities in [t] with 35m main boom

Radius [m]	Jib length [m]			
	11	14	20	26
7	35.9			
8	35.9	35.9		
10	35.9	35.3	30.2	
13	35.9	33.8	27.4	18.9
18	35.9	31.5	24.0	16.5
24	34.1	28.5	20.4	14.3
30	25.1	25.3	17.3	13.0
38	17.8	18.1	14.2	10.8
42	15.3	15.6	13.1	10.0
46		13.4	12.3	9.2
50			11.8	8.7
55				8.1

82.3t rear counterweight and 36t carbody counterweight

### Load capacities in [t] with 50m main boom

Radius [m]	Jib length [m]			
	11	14	20	26
6.7	35.9			
8	35.9	35.4		
11	35.9	34.1	27.5	
13	35.9	33.3	26.2	18.3
18	35.9	31.5	23.3	16.3
24	32.5	28.5	20.8	14.5
30	24.0	24.4	19.0	13.4
38	16.7	17.0	16.2	12.1
50	10.4	10.6	11.1	10.0
55	8.6	8.8	9.3	9.2
65			6.4	6.8
70				5.6

82.3t rear counterweight and 36t carbody counterweight

### Load capacities in [t] with 65m main boom

Radius [m]	Jib length [m]			
	11	14	20	26
7.2	35.9			
9	35.9	33.6		
11	35.9	33.0	25.4	
14	35.7	31.8	24.2	17.0
20	31.8	28.7	21.6	15.0
28	24.4	24.5	19.4	13.5
44	12.1	12.3	12.9	11.6
55	7.5	7.8	8.2	8.7
65	4.8	5.0	5.4	5.8
70		3.9	4.3	4.6
75			3.3	3.7
80				2.8

82.3t rear counterweight and 36t carbody counterweight

### Load capacities in [t] with 74m main boom

Radius [m]	Jib length [m]		
	11	14	17
7.6	35.1		
9	34.3	31.1	
10	32.8	30.8	27.8
14	30.6	27.4	24.9
24	26.2	24.1	22.2
32	19.0	19.2	19.4
40	13.4	13.6	13.9
48	9.4	9.7	10.0
50	8.6	8.9	9.2
65	4.0	4.2	4.5
70	2.9	3.2	3.4
75	2.0	2.2	2.4

82.3t rear counterweight and 36t carbody counterweight

TLT 11962152. Above load charts are for reference only. For actual lift duty please refer to load chart in operator's cabin or manual. Otherwise we recommend you to plan your lifting job using Crane Planner 2.0.



[www.liebherr.com/CranePlanner](http://www.liebherr.com/CranePlanner)

**Crane Planner 2.0**

## Load capacities with fixed jib 30°

### Load capacities in [t] with 20m main boom

Radius [m]	Jib length [m]			
	11	14	20	26
11	34.8			
12	32.7	26.9		
13	31.2	26.1		
14	29.8	24.7		
16	27.1	23.7	16.4	
18	25.1	21.6	15.1	12.1
20	24.0	20.1	14.0	11.3
22	22.8	18.7	13.0	10.5
30	19.0	15.2	10.7	8.3
32		14.8	10.2	7.9
40			9.1	6.8
46				6.4

82.3t rear counterweight and 36t carbody counterweight

### Load capacities in [t] with 35m main boom

Radius [m]	Jib length [m]			
	11	14	20	26
8.8	35.9			
11	35.9	29.0		
13	34.3	27.9		
16	30.8	25.6	17.3	
18	28.9	24.0	16.2	
20	27.2	23.6	15.4	11.7
28	23.4	19.2	12.7	9.5
36	19.6	16.6	11.2	8.2
44	14.2	14.6	9.9	7.3
46		13.5	9.7	7.1
50			9.5	6.8
55				6.6

82.3t rear counterweight and 36t carbody counterweight

### Load capacities in [t] with 50m main boom

Radius [m]	Jib length [m]			
	11	14	20	26
9.4	35.9			
12	35.9	28.0		
14	34.6	27.3		
16	32.9	25.9	16.9	
18	31.2	24.8	16.2	
20	29.9	24.0	15.5	11.7
36	18.6	18.1	12.1	8.8
44	13.4	13.7	10.7	7.9
55	8.7	9.0	9.5	7.1
60		7.3	7.9	6.8
65			6.5	6.6
70				5.8

82.3t rear counterweight and 36t carbody counterweight

### Load capacities in [t] with 65m main boom

Radius [m]	Jib length [m]			
	11	14	20	26
9.9	32.8			
12	31.9	26.7		
16	29.6	25.0	17.4	
20	27.5	23.6	16.3	11.7
30	23.0	20.1	13.8	9.9
42	13.5	13.9	12.1	8.5
55	7.7	8.1	8.7	7.5
60	6.2	6.5	7.1	7.2
65	4.9	5.1	5.7	6.2
70	3.7	4.0	4.5	5.0
75			3.4	3.9
85				2.0

82.3t rear counterweight and 36t carbody counterweight

### Load capacities in [t] with 74m main boom

Radius [m]	Jib length [m]		
	11	14	17
10.2	28.8		
13	26.0	24.1	
14	25.1	24.0	20.4
22	23.5	20.8	18.5
30	21.1	18.5	16.4
38	15.2	15.5	14.7
46	10.8	11.1	11.5
55	7.1	7.4	7.8
60	5.5	5.8	6.2
65	4.2	4.5	4.8
70	3.1	3.3	3.6
75	2.1	2.3	2.6

82.3t rear counterweight and 36t carbody counterweight

TLT 11962152. Above load charts are for reference only. For actual lift duty please refer to load chart in operator's cabin or manual. Otherwise we recommend you to plan your lifting job using Crane Planner 2.0.



[www.liebherr.com/CranePlanner](http://www.liebherr.com/CranePlanner)

**Crane Planner 2.0**

# Fixed jib 0806.xx

Jib lengths 11-32 m

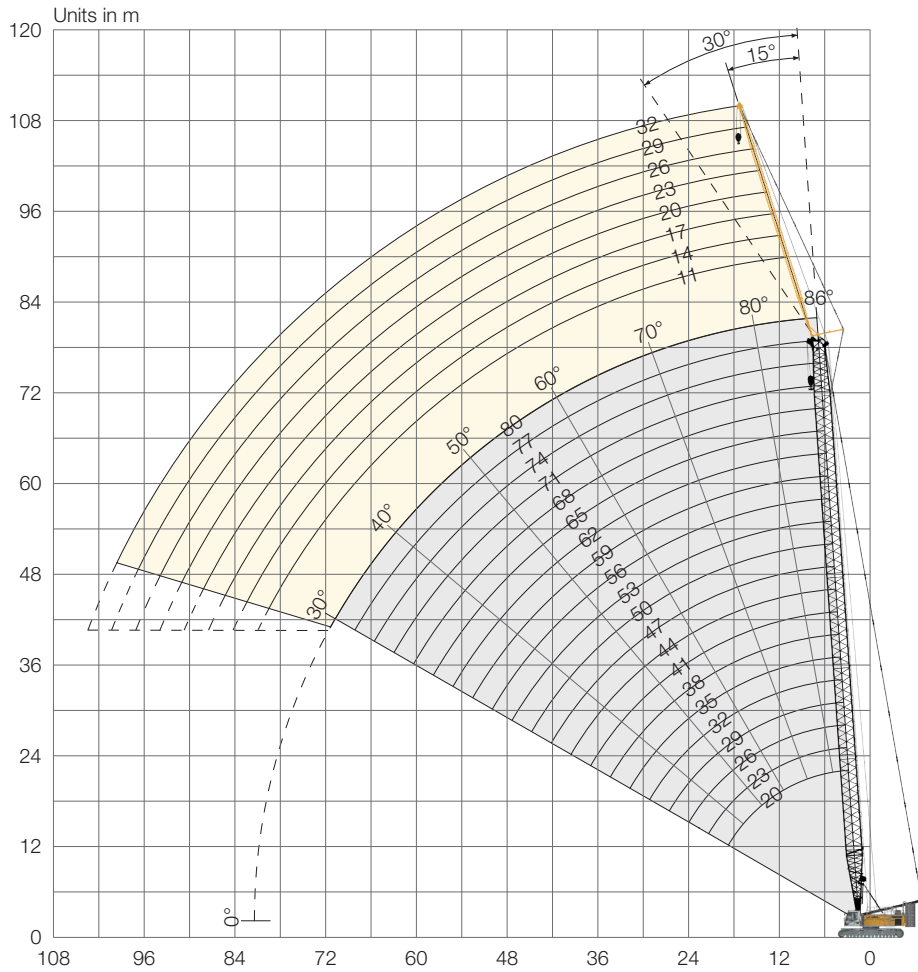

## Jib configuration 0806.xx

Jib section	Amount of jib sections							
Jib foot 5.5 m	1	1	1	1	1	1	1	1
Jib section 3 m		1		1		1		1
Jib section 6 m			1	1	2	2	3	3
Jib head 5.5 m	1	1	1	1	1	1	1	1
<b>Jib length [m]</b>	<b>11</b>	<b>14</b>	<b>17</b>	<b>20</b>	<b>23</b>	<b>26</b>	<b>29</b>	<b>32</b>

For main boom configuration please refer to the table on page 18.

# Load capacities with fixed jib 15°

## Load capacities in [t] with 20m main boom

Radius [m]	Jib length [m]				
	11	17	23	29	32
11	20.5				
13	19.6	12.5			
16	18.4	11.8	9.1	6.5	
18	17.7	11.3	8.8	6.2	5.1
22	16.6	10.5	8.2	5.8	4.6
26	15.7	9.9	7.7	5.4	4.3
30	14.6	9.5	7.3	5.0	4.0
34		8.9	6.9	4.8	3.7
38			6.5	4.5	3.5
42			6.0	4.3	3.3
48				4.1	3.2
50					3.1

82.3t rear counterweight and 36t carbody counterweight

## Load capacities in [t] with 35m main boom

Radius [m]	Jib length [m]				
	11	17	23	29	32
8	22.7				
10	22.1	13.6			
12	21.4	13.2	9.7		
14	20.9	12.7	9.4	6.7	
20	19.2	11.6	8.8	6.1	4.9
28	17.3	10.5	8.0	5.5	4.3
36	16.0	9.7	7.4	4.9	3.9
40	15.1	9.4	7.1	4.7	3.7
44		9.0	6.9	4.5	3.5
50			6.4	4.3	3.3
55			6.0	4.2	3.2
60				4.1	3.1

82.3t rear counterweight and 36t carbody counterweight

## Load capacities in [t] with 50m main boom

Radius [m]	Jib length [m]				
	11	17	23	29	32
6.7	21.1				
10	20.5	12.6			
12	20.2	12.3	8.8		
14	19.7	12.0	8.6	6.1	
16	19.3	11.8	8.5	6.0	4.9
34	17.1	10.1	7.4	5.1	4.0
46	12.8	9.5	7.0	4.6	3.6
55	9.3	9.0	6.7	4.3	3.3
60		8.4	6.4	4.1	3.2
65			6.2	4.1	3.1
70				4.0	3.1
75					3.0

82.3t rear counterweight and 36t carbody counterweight

## Load capacities in [t] with 65m main boom

Radius [m]	Jib length [m]				
	11	17	23	29	32
7.2	18.6				
10	18.3	11.7			
13	18.0	11.4	7.9		
16	17.7	11.2	7.8	5.4	4.4
24	17.0	10.6	7.4	5.1	4.2
32	16.4	10.1	7.1	4.9	4.0
48	10.9	9.4	6.6	4.5	3.6
65	5.5	6.1	6.4	4.2	3.3
70		5.0	5.5	4.1	3.2
80			3.6	4.0	3.1
85				3.3	3.1
90					2.7

82.3t rear counterweight and 36t carbody counterweight

## Load capacities in [t] with 80m main boom

Radius [m]	Jib length [m]				
	11	14	17	20	23
7.8	14.9				
9	14.9	11.6			
11	14.8	11.6	9.0		
12	14.7	11.5	9.0	7.6	
20	14.2	11.1	8.7	7.4	6.0
28	13.7	10.8	8.4	7.2	5.9
36	13.3	10.6	8.2	7.1	5.8
44	11.4	10.2	8.1	7.0	5.7
55	7.1	7.4	7.7	6.9	5.5
65	4.3	4.6	4.9	5.2	5.2
70	3.3	3.6	3.8	4.1	4.4
80			2.1	2.3	2.5

82.3t rear counterweight and 36t carbody counterweight

TLT 11962152. Above load charts are for reference only. For actual lift duty please refer to load chart in operator's cabin or manual. Otherwise we recommend you to plan your lifting job using Crane Planner 2.0.



[www.liebherr.com/CranePlanner](http://www.liebherr.com/CranePlanner)

**Crane Planner 2.0**

# Load capacities with fixed jib 30°

## Load capacities in [t] with 20m main boom

Radius [m]	Jib length [m]				
	11	17	23	29	32
13	17.6				
16	16.8	10.6			
20	16.0	10.1	7.8		
22	15.5	9.9	7.6	5.3	
24	14.6	9.7	7.4	5.2	4.1
28	13.3	9.2	7.0	4.9	3.8
30	12.9	8.8	6.8	4.7	3.7
32		8.5	6.6	4.6	3.6
36		8.0	6.1	4.4	3.4
42			5.7	4.2	3.3
48				4.1	3.1
50					3.1

82.3t rear counterweight and 36t carbody counterweight

## Load capacities in [t] with 35m main boom

Radius [m]	Jib length [m]				
	11	17	23	29	32
11	18.9				
14	18.2	11.1			
18	17.4	10.7	8.1		
20	17.0	10.4	7.9		
24	16.4	10.1	7.6	5.2	4.1
34	14.2	9.5	7.0	4.7	3.7
36	13.8	9.2	6.8	4.6	3.6
42	12.9	8.5	6.4	4.4	3.4
46		8.2	6.0	4.3	3.3
55			5.7	4.2	3.2
60				4.2	3.1
65					3.1

82.3t rear counterweight and 36t carbody counterweight

## Load capacities in [t] with 50m main boom

Radius [m]	Jib length [m]				
	11	17	23	29	32
9.4	18.2				
14	17.7	10.7			
18	17.3	10.5	7.7		
20	17.2	10.3	7.6		
22	17.0	10.2	7.6	5.2	
24	16.8	10.1	7.5	5.1	4.0
42	14.4	9.3	6.8	4.5	3.4
55	9.4	8.3	6.0	4.2	3.2
60		8.1	5.9	4.1	3.2
65			5.7	4.1	3.1
70				4.1	3.1
75				4.1	3.1

82.3t rear counterweight and 36t carbody counterweight

## Load capacities in [t] with 65m main boom

Radius [m]	Jib length [m]				
	11	17	23	29	32
9.9	16.5				
14	16.3	10.2			
18	16.2	10.1	7.2		
22	16.2	9.9	7.1	4.9	
32	16.0	9.6	6.9	4.7	3.8
42	14.3	9.3	6.8	4.5	3.6
55	8.5	8.8	6.5	4.3	3.3
65	5.6	6.3	6.0	4.2	3.2
75		4.1	4.7	4.2	3.2
80			3.7	4.2	3.2
85				3.4	3.2
90					2.8

82.3t rear counterweight and 36t carbody counterweight

## Load capacities in [t] with 80m main boom

Radius [m]	Jib length [m]				
	11	14	17	20	23
10.4	13.9				
13	13.9	11.2			
16	13.8	11.2	8.7	7.6	
18	13.8	11.1	8.6	7.6	6.0
28	13.6	11.0	8.5	7.4	5.9
38	13.4	10.9	8.5	7.3	5.8
44	11.7	10.4	8.5	7.2	5.8
46	10.9	10.1	8.5	7.2	5.8
50	9.3	9.6	8.5	7.1	5.8
55	7.4	7.8	8.2	7.0	5.8
75	2.5	2.8	3.1	3.4	3.7
80			2.2	2.5	2.8

82.3t rear counterweight and 36t carbody counterweight

TLT 11962152. Above load charts are for reference only. For actual lift duty please refer to load chart in operator's cabin or manual. Otherwise we recommend you to plan your lifting job using Crane Planner 2.0.



[www.liebherr.com/CranePlanner](http://www.liebherr.com/CranePlanner)

**Crane Planner 2.0**

# Fixed jib 0906.21

Jib length 7 m

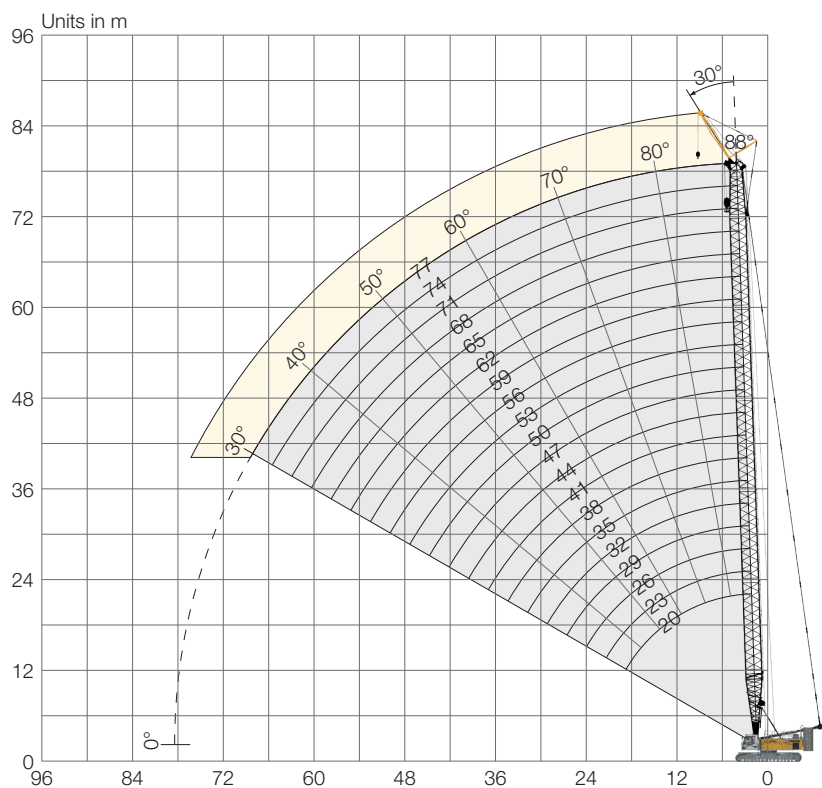

The jib length is 7 m, for main boom configuration please refer to the table on page 18.

## Load capacities with fixed jib 30°

### Load capacities in [t] with 20m main boom

Radius [m]	Jib length 7 m
10	59.2
11	57.6
12	56.2
13	54.7
14	53.6
16	51.6
18	50.0
20	44.3
22	39.0
24	34.6
26	30.9

82.3t rear counterweight and 36t carbody counterweight

### Load capacities in [t] with 35m main boom

Radius [m]	Jib length 7 m
8	70.7
13	69.3
14	67.0
15	62.1
16	57.8
20	43.7
24	34.0
28	27.4
32	22.6
36	18.9
40	16.0

82.3t rear counterweight and 36t carbody counterweight

### Load capacities in [t] with 50m main boom

Radius [m]	Jib length 7 m
7.9	69.1
9	68.3
11	65.2
16	52.6
20	41.0
24	33.0
32	21.7
40	15.1
44	12.8
48	10.9
50	10.0

82.3t rear counterweight and 36t carbody counterweight

### Load capacities in [t] with 65m main boom

Radius [m]	Jib length 7 m
8.4	48.8
12	46.3
18	40.2
22	33.5
26	27.2
30	22.6
34	18.8
38	15.6
42	13.0
48	9.9
65	4.4

82.3t rear counterweight and 36t carbody counterweight

### Load capacities in [t] with 77m main boom

Radius [m]	Jib length 7 m
8.8	34.3
14	32.4
18	30.8
22	28.2
28	22.8
34	17.2
38	14.3
40	13.1
46	10.0
55	6.4
70	2.4

82.3t rear counterweight and 36t carbody counterweight

TLT 11962152. Above load charts are for reference only. For actual lift duty please refer to load chart in operator's cabin or manual. Otherwise we recommend you to plan your lifting job using Crane Planner 2.0.



[www.liebherr.com/CranePlanner](http://www.liebherr.com/CranePlanner)

 **Crane Planner 2.0**

# The Liebherr Group of Companies



## Wide Product Range

The Liebherr Group is one of the largest construction equipment manufacturers in the world. Liebherr's high-value products and services enjoy a high reputation in many other fields. The wide range includes domestic appliances, aerospace and transportation systems, machine tools and maritime cranes.

## Exceptional Customer Benefit

Every product line provides a complete range of models in many different versions. With both their technical excellence and acknowledged quality, Liebherr products offer a maximum of customer benefits in practical applications.

## State-of-the-art Technology

To provide consistent, top quality products, Liebherr attaches great importance to each product area, its components and core technologies. Important modules and components are developed and manufactured in-house, for instance the entire drive and control technology for construction equipment.

## Worldwide and Independent

Hans Liebherr founded the Liebherr family company in 1949. Since then, the family business has steadily grown to a group of more than 130 companies with nearly 44,000 employees located on all continents. The corporate headquarters of the Group is Liebherr-International AG in Bulle, Switzerland. The Liebherr family is the sole owner of the company.

[www.liebherr.com](http://www.liebherr.com)



Please contact us.



Download datasheet

## Liebherr-Werk Nenzing GmbH

Dr. Hans Liebherr Str. 1, 6710 Nenzing/Austria  
☎ +43 50809 41-473, Fax: +43 50809 41-499  
[www.liebherr.com](http://www.liebherr.com), [crawler.crane@liebherr.com](mailto:crawler.crane@liebherr.com)  
[facebook.com/LiebherrConstruction](https://www.facebook.com/LiebherrConstruction)